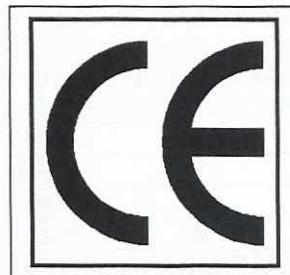




**CONDENSATORI PER FORNI A INDUZIONE**  
**INDUCTION HEATING CAPACITORS**  
**CAPACITORS IN TOUCH WITH YOUR NEEDS**



**QUALITA'**  
**DI SISTEMA DI PROCESSO E DI PRODOTTO**



THE INTERNATIONAL CERTIFICATION NETWORK

**CERTIFICATE**

IQNet and its partner  
**CISQ/IMQ-CSQ**  
 hereby certify that the organization

**INCO MASSALOMBARDA S.r.l.**

VIA MARCHETTI 88 - 48024 MASSA LOMBARDA (RA)

for the following field of activities

*Designing and manufacturing of LV, MV and HV capacitors;  
 electrical and electromechanical disconnectors;*

*LV, MV and AT automatic power factor correction systems with or without presence of harmonics;  
 pulse forming network and LV, MV and HV harmonic filters*

*Refer to quality manual for details of applications to ISO 9001:2008 requirements*

has implemented and maintains a

**Quality Management System**

which fulfills the requirements of the following standard

**ISO 9001:2008**

Issued on: 2013 - 06 - 10

Expiry date: 2016 - 06 - 10

Registration Number: **IT - 37335**



www.imq.it

CERTIFICATO N. **9101.INCO**  
 CERTIFICATE N.

SI CERTIFICA CHE IL SISTEMA QUALITA' DI  
 WE HEREBY CERTIFY THAT THE QUALITY SYSTEM OPERATED BY

**INCO MASSALOMBARDA S.r.l.**

VIA MARCHETTI 88 - 48024 MASSA LOMBARDA (RA)

UNITA' OPERATIVE

OPERATIVE UNITS

VIA MARCHETTI 88 - 48024 MASSA LOMBARDA (RA)

E' CONFORME ALLA NORMA

IS IN COMPLIANCE WITH THE STANDARD

**ISO 9001:2008**

PER LE SEGUENTI ATTIVITA'  
 FOR THE FOLLOWING ACTIVITIES

Progettazione e fabbricazione di condensatori in BT, MT e AT;  
 disgiunti elettromeccanici ed elettronici;  
 impianti automatici per il rifasamento in BT, MT e AT con e senza abbattimento di armoniche;  
 linee formatrici impulsi e filtri per armoniche in BT, MT e AT  
*Designing and manufacturing of LV, MV and HV capacitors;  
 electrical and electromechanical disconnectors;  
 LV, MV and AT automatic power factor correction systems with or without presence of  
 harmonics;  
 pulse forming network and LV, MV and HV harmonic filters*

Riferirsi al manuale della qualità per l'applicabilità dei requisiti della norma ISO 9001:2008  
 Refer to quality manual for details of applications to ISO 9001:2008 requirements

IL PRESENTE CERTIFICATO E SOGGETTO AL RISPETTO DEL  
 REGOLAMENTO PER LA CERTIFICAZIONE DEI SISTEMI DI GESTIONE  
 THE USE AND THE VALIDITY OF THE CERTIFICATE SHALL SATISFY THE  
 REQUIREMENTS OF THE RULES FOR CERTIFICATION OF MANAGEMENT SYSTEMS

DATE	PRIMA CERTIFICAZIONE FIRST CERTIFICATION	EMISSIONE CORRENTE CURRENT ISSUE	SCADENZA EXPIRY
2004-06-11	2013-06-10	2016-06-10	

*Ing. Claudio Provetti*

IMQ S.p.A. - VIA QUINTILIANO, 43 - 20138 MILANO ITALY

CISQ is a member of



IQNet, the association of the world's first  
 class certification bodies, is the largest  
 provider of management system  
 Certification in the world.  
 IQNet is composed of more than 30  
 bodies and counts over 150 subsidiaries  
 all over the globe.



*Michael Drechsel*  
 Michael Drechsel  
 President of IQNET



*Ing. Claudio Provetti*  
 Ing. Claudio Provetti  
 President of CISQ

IQNet Partners\*  
 AENOR Spain AFNOR Certification France AIB-Vincotte International Belgium ANCE-SIGE Mexico APCER Portugal CCC Cyprus  
 CISQ Italy CQC China CQM China COS Czech Republic Cro Cert Croatia DOS Holding GmbH Germany DS Denmark  
 FCAV Brazil FONDONORMA Venezuela ICONTEC Colombia IMNC Mexico INNORPI Tunisia  
 Inspecta Certification Finland IRAM Argentina IQA Japan KIFU Korea MIRTEC Greece MSZT Hungary Nemko AS Norway  
 NSAI Ireland PCBC Poland Quality Austria Austria RR Russia SH Israel SIQ Slovenia SIRIM QAS International Malaysia  
 SQS Switzerland SRAC Romania TEST St Petersburg Russia TSE Turkey YUQS Serbia  
 IQNet is represented in the USA by: AFNOR Certification, CISQ, IQS Holding GmbH and NSAI Inc.

\* The list of IQNet partners is valid at the time of issue of this certificate. Updated information is available under www.iqnet-certification.com



EA: 19

SECONDA SPA (INCO)  
 SCRIVIA (SP) (SOLVITEC)  
 PIAVE (PD) (PULTEC)  
 VENEZIA (VE) (VETEC)

La validità del certificato è subordinata al mantenimento attuale e costante controllo del Sistema di Gestione di Qualità con certificazione triennale.  
 The validity of the certificate is subordinate to current and constant control of the Quality Management System within three years.

CISQ è la Federazione Italiana di  
 Organismi di Certificazione del  
 sistema di gestione aziendale.  
 CISQ is the Italian Federation  
 of management system  
 Certification Bodies.



www.cisq.it/01





**CONDENSATORI PER FORNI A INDUZIONE**  
**INDUCTION HEATING CAPACITORS**  
**CAPACITORS IN TOUCH WITH YOUR NEEDS**



**Pagine / Pages**

1	<b>CERTIFICAZIONI</b> <i>CERTIFICATION</i>		
3	<b>OBIETTIVI</b> <i>AIMS</i>		
4	<b>LINEE DI PRODOTTI INCO ATTUALMENTE DISPONIBILI</b> <i>INCO PRODUCTS LINES ACTUALLY AVAILABLE</i>		
5	<b>CONDENSATORI PER BASSA, MEDIA E ALTA FREQUENZA</b> <i>LOW, MEDIUM, AND HIGH FREQUENCY CAPACITORS</i>		
6	<b>CARATTERISTICHE DI PRODOTTO E DI PROCESSO</b> <i>PRODUCT AND PRODUCTION FEATURES</i>		
	6	<b>ARMATURE</b>	<i>FOILS</i>
	7	<b>IMPREGNANTE</b>	<i>IMPREGNANTIG</i>
	7	<b>CUSTODIE</b>	<i>CASES</i>
	8	<b>RAFFREDDAMENTO</b>	<i>COOLING</i>
9	<b>RAFFREDDAMENTO NATURALE</b> <i>NATURAL COOLING</i>		
	11	<b>I-LFA</b> $f = 50/60\text{Hz}$	<i>I-LFA</i> $f = 50/60\text{Hz}$
	11	<b>I-MFA</b> $f \leq 24 \text{ kHz}$	<i>I-MFA</i> $f \leq 24 \text{ kHz}$
12	<b>RAFFREDDAMENTO CON ACQUA</b> <i>WATER COOLING</i>		
	16	<b>I-LFW</b> $f < 1 \text{ kHz}$	<i>I-LFW</i> $f < 1 \text{ kHz}$
	16	<b>I-MFW</b> $1 \text{ kHz} \leq f \leq 24 \text{ kHz}$	<i>I-MFW</i> $1 \text{ kHz} \leq f \leq 24 \text{ kHz}$
	16	<b>I-HFW</b> $f > 24 \text{ kHz}$	<i>I-HFW</i> $f > 24 \text{ kHz}$
17	<b>CONDIZIONI E OPERAZIONI DI MONTAGGIO</b> <i>CONDITIONS AND ASSEMBLING OPERATIONS.</i>		
22	<b>HFAL.AZ.CC(D) – HFCU.AZ.CC(D) CONDENSATORI PER ALTA FREQUENZA E BASSA INDUTTANZA</b> <i>HFAL.AZ.CC(D) – HFCU.AZ.CC(D) CAPACITORS FOR HIGH FREQUENCY AND LOW INDUCTANCE</i>		
	29	$\varnothing 80 \times 71,5$	
	31	$\varnothing 100 \times 71,5$	
	33	$\varnothing 125 \times 71,5$	
	<b>HFCU.AA.CC(D) CONDENSATORI PER ALTA FREQUENZA E BASSA INDUTTANZA</b> <i>HFCU.AA.CC(D) CAPACITORS FOR HIGH FREQUENCY AND LOW INDUCTANCE</i>		
	35	$\varnothing 50 \times 71,5$	
	37	$\varnothing 80 \times 71,5$	
	<b>HFCU.AZ.CC(D) - HFCU.AA.CC(D) CONDENSATORI PER ALTA FREQUENZA E BASSA INDUTTANZA</b> <i>HFCU.AZ.CC(D) - HFCU.AA.CC(D) CAPACITORS FOR HIGH FREQUENCY AND LOW INDUCTANCE</i>		
	39	$150 \times 150 \times 78,5$	
46	<b>COMPLETAMENTO DI SISTEMA</b> <i>SYSTEM FINISHING</i>		
	47	<b>I-SM</b> PER THYRISTOR (SCR), SNUBBER/DAMPING E FILTRAGGIO.	<i>I-SM</i> FOR THYRISTOR (SCR), SNUBBER/DAMPING AND FILTERING.
	48	<b>I-HCCR</b> <b>COMMUTAZIONE</b>	<i>I-HCCR</i> <b>COMMUTATION</b>
	49	<b>I-FC 90</b> <b>FILTRO</b>	<i>I-FC 90</i> <b>FILTER</b>
	50	<b>I-FCR-HFR-2W</b> <b>FILTRO</b>	<i>I-FCR-HFR-2W</i> <b>FILTER</b>
		<b>I-FCR-HFR-RE</b> <b>FILTRO</b>	<i>I-FCR-HFR-RE</i> <b>FILTER</b>
		<b>I-FCH-HFR-2W</b> <b>FILTRO</b>	<i>I-FCH-HFR-2W</i> <b>FILTER</b>





# CONDENSATORI PER FORNI A INDUZIONE INDUCTION HEATING CAPACITORS CAPACITORS IN TOUCH WITH YOUR NEEDS



## INCO MASSALOMBARDA srl: GLI OBIETTIVI OBJECTIVES

### MISSIONE

Essere tra i protagonisti mondiali nel soddisfare tutti i bisogni del mercato dei condensatori elettrici con prodotti e servizi di **QUALITA'**.  
Contribuire al miglioramento della **QUALITA'** della vita, concentrando ogni sforzo sull'innovazione e sul miglioramento continuo dei prodotti e dei servizi offerti ai **CLIENTI**.

### MISSION

*To be among world protagonists in satisfying world electrical capacitors needs with **QUALITY** products and services.*

*To contribute to improve life **QUALITY**, concentrating any effort on innovation and continuous improvement of products.*

### INNOVARE

L'arte e il mestiere contano molto e possono produrre eccellenti risultati, con o senza quei rari e straordinari momenti di intuizione o di innovazione che portano a qualcosa di veramente innovativo.

### INNOVATION

*The art and experience are very important and can have excellent results, with or without rare and unusual moments of intuition or innovation that approach something really innovative.*

### CREARE

La creatività non è un bene in vendita e nasce da un incontro fortunato di intuizione e fiducia che integra nuove idee in un processo che genera valore: strumento principale della capacità nella competizione.

### CREATING

*Creativity is not something for sale and it comes from a lucky meeting between perception and trust that integrates new ideas in a process that will create value: the most important instrument of ability in competition.*

## MISSIONE E STRATEGIE DELLA FILOSOFIA AZIENDALE.

INCO MASSALOMBARDA srl è protesa costantemente al miglioramento della **QUALITA'** e al soddisfacimento del **CLIENTE**.

La politica aziendale è mirata ad una sintesi tra le tecnologie più sofisticate, tipiche delle grandi aziende, e la flessibilità produttiva e di servizio tipiche dell'impresa di medie dimensioni.

L'obiettivo finale è l'ottenimento di un ottimo servizio abbinato ad un alto rapporto **QUALITA' / COSTO**. Gli investimenti recenti e quelli attuali sono rivolti ad ottenere una maggiore potenzialità produttiva ed una elevata flessibilità tale da poter offrire al mercato tempi di consegna di 3 giorni per l'**ITALIA** e 7 giorni per l'**EUROPA** previo accordi particolari con il **CLIENTE**. Tale potenzialità di consegna a breve ci è consentita in quanto la Direzione ha deciso di investire per operare sul mercato con il "**JUST IN TIME**".

Per potere accelerare i processi di realizzazione del prodotto, la produzione è stata organizzata e suddivisa in "linee" ed "isole".

## MISSION AND STRATEGY OF COMPANY PHILOSOPHY

INCO MASSALOMBARDA srl is constantly leaned to increase **QUALITY** and **CUSTOMER SATISFACTION**.

The line of action is finalized to a synthesis between more sophisticated technology, typical in a big company, and the production sequence and service of a medium firm.

The final objective is the achievement of an excellent service and of an high ratio **QUALITY/COST**.

The latest investments and the actual ones are finalized to obtain a better production power and an high flexibility to offer to the market 3 days delivery time for **ITALY** and 7 days for **EUROPE** previous agreements with **CUSTOMER**. Such delivery time potentiality is permitted for the reason Direction decided investisment to operate on the market with "**JUST IN TIME**".

To accelerate production processes to realize products, the production has been organized and divided in "lines" and "isles".



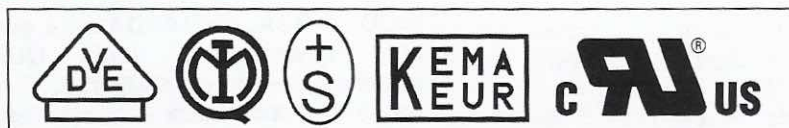


**CONDENSATORI PER FORNI A INDUZIONE**  
**INDUCTION HEATING CAPACITORS**  
**CAPACITORS IN TOUCH WITH YOUR NEEDS**



**LINEE DI PRODOTTI INCO ATTUALMENTE DISPONIBILI**  
**INCO PRODUCTS LINES ACTUALLY AVAILABLE**

- **CE** **CONDENSATORI STATICI PER MOTORI.**  
*AC MOTOR CAPACITORS.*



- **CE** **CONDENSATORI PER LAMPADE.**  
*LAMP CAPACITORS.*



- **CE** **CONDENSATORI DI SWITCHING ( DISGIUNTORI ).**  
*SWITCHING CAPACITORS.*



- **CE** **CONDENSATORI DI RIFASAMENTO PER APPLICAZIONI IN BASSA, MEDIA, ALTA TENSIONE.**  
*POWER FACTOR CORRECTION CAPACITORS FOR APPLICATION IN LOW, MEDIUM AND HIGH VOLTAGE.*
- **CE** **FILTRI PER LA SOPPRESSIONE DI CORRENTI ARMONICHE IN BASSA, MEDIA E ALTA TENSIONE.**  
*FILTERS FOR SUPPRESSION OF HARMONIC CURRENTS IN LOW, MEDIUM AND HIGH VOLTAGE*
- **CE** **IMPIANTI DI RIFASAMENTO FISSI E AUTOMATICI PER APPLICAZIONI CON TENSIONI  $\leq 1000 V_{AC}$ .**  
*POWER FACTOR CORRECTION PLANTS WITH FIXED OR AUTOMATIC SOLUTIONS AND VOLTAGES  $\leq 1000 V_{AC}$ .*
- **CE** **CONDENSATORI PER FORNI A INDUZIONE CON APPLICAZIONI IN BASSA, MEDIA E ALTA FREQUENZA CON RAFFREDDAMENTO AD ARIA E CON RAFFREDDAMENTO AD ACQUA.**  
*CAPACITORS FOR INDUCTION FURNACES WITH APPLICATIONS IN LOW, MEDIUM AND HIGH FREQUENCY WITH AIR COOLED AND WATER COOLED SOLUTIONS.*
- **CE** **CONDENSATORI PER ELETTRONICA DI POTENZA CON APPLICAZIONI IN ALTA FREQUENZA CON RAFFREDDAMENTO AD ARIA E CON RAFFREDDAMENTO AD ACQUA.**  
*POWER ELECTRIC CAPACITORS FOR APPLICATIONS IN HIGH FREQUENCY WITH AIR COOLED AND WATER COOLED SOLUTIONS.*
- **CE** **LINEE FORMATRICI DI IMPULSI PER STAZIONI RADAR.**  
*PULSING FORMING NETWORK FOR RADAR APPLICATIONS.*





**CONDENSATORI PER FORNI A INDUZIONE**  
**INDUCTION HEATING CAPACITORS**  
**CAPACITORS IN TOUCH WITH YOUR NEEDS**



**CONDENSATORI DI BASSA, MEDIA E ALTA FREQUENZA**  
**LOW, MEDIUM, AND HIGH FREQUENCY CAPACITORS**



**In situazioni di fusione o riscaldamento ad induzione normalmente riscontrabili nei settori relativi a:**

- **TRATTAMENTI TERMICI**
- **SALDATURA E SALDOBRASTURA**
- **ASSEMBLAGGIO A CALDO E FUSIONE**

il progettista deve fare uso di correnti ad alta frequenza con una caduta ohmica lungo le spire molto bassa se confrontata con la caduta induttiva della spira stessa. Da ciò consegue un elevato abbassamento del fattore di potenza del circuito che rende necessario l'utilizzo di un alto valore di corrente inverso per cui i condensatori statici per media e alta frequenza con raffreddamento naturale o con raffreddamento forzato ad acqua sono chiamati ad operare.

*In situations of melting or induction heating usually found in sectors as:*

- *HEAT TREATMENT*
- *WELDING AND INDUCTION BRAZING*
- *HEAT ASSEMBLING AND MELTING*

*designer engineers must use very high frequency currents with very low ohmic losses of turns if compared with inductive loss of turns themselves. In this situation the circuit has a very high fall of the circuit power factor so that the use a very high value of inversed current is required, then the static capacitors for medium and high frequency with natural cooling or forced water cooling are required to solve the situation.*

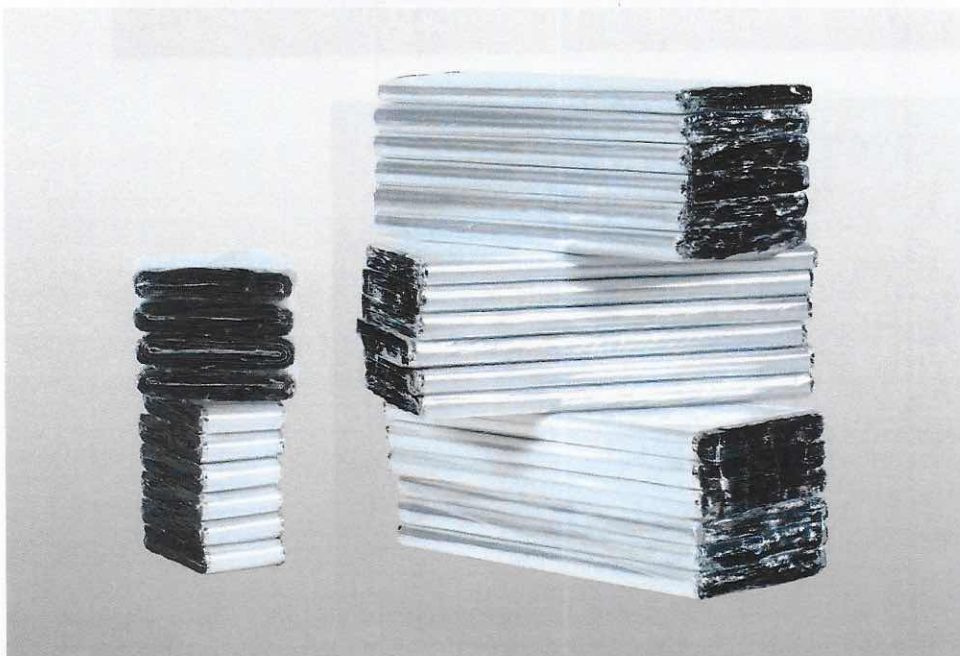




# CONDENSATORI PER FORNI A INDUZIONE INDUCTION HEATING CAPACITORS CAPACITORS IN TOUCH WITH YOUR NEEDS



## CARATTERISTICHE DI PRODOTTO E DI PROCESSO PRODUCT AND PRODUCTION FEATURES



### ARMATURE

Due sono i tipi di armature utilizzabili; la scelta è effettuata a livello di progetto ed è strettamente legata alle caratteristiche di prodotto e utilizzo indicate dal Cliente:

- **ARMATURA METALLIZZATA**

l'armatura metallizzata è definita **AUTORIGENERABILE** in quanto il dielettrico è formato da un sottile foglio di polipropilene su cui è stato depositato sotto vuoto spinto un basso spessore di metallo (Ag ; Zn) con lo scopo di creare l'armatura. Quando per la presenza di particelle conduttive, punti deboli, sovratensioni o sovracorrenti si presenta un punto di corto circuito, tra le armature di un condensatore si genera un arco elettrico che da origine a un processo di evaporazione del metallo nell'area oggetto del problema creando una piccola zona senza metallo, che quindi ripristina l'isolamento iniziale tra le armature.

### FOILS

There are two kinds of usable foils: the choice is carried out at planning level and it's tightly connected to product features and utilization indicated by Customer.

- **METALLIZED FOIL**

The metallized foil is defined **SELF-HEALING** because the dielectric is a thin polypropylene sheet on which, under vacuum, a low metal thin ( Ag ; Zn ) has been placed to create the foil. When for the presence of conductive particles or weak points, overvoltages or overcurrents a short circuit point is generated, an electric arc is created between the two capacitor foils, and an evaporation process of the metal located in the area of the problem is forced creating a small zone without metal and resetting the initial insulation between the foils.





## CONDENSATORI PER FORNI A INDUZIONE INDUCTION HEATING CAPACITORS CAPACITORS IN TOUCH WITH YOUR NEEDS



- **ARMATURA PESANTE**

L'armatura **NON È AUTORIGENERABILE** ed è definita pesante in quanto al dielettrico di polipropilene sono abbinati fogli di alluminio di alta purezza il cui spessore è strettamente condizionato dagli elevatissimi valori di corrente e di potenza reattiva di servizio.

### IMPREGNANTE

- **RESINA**

Utilizzata esclusivamente per condensatori in armatura metallizzata e che permette di "affogare" in resina poliuretana la parte capacitiva assicurandone il riempimento e la protezione dall'esterno.

- **OLIO IMPREGNANTE**

È un olio sintetico, biodegradabile, non tossico con eccellenti prestazioni elettriche, valori di break-down molto elevati e un bassissimo fattore di dissipazione utilizzato esclusivamente per condensatori ad armatura pesante.

**Il fluido non contiene PCB.**

### CUSTODIE

- Per condensatori serie HFCU le custodie utilizzate sono in rame (Cu).
- Per condensatori serie LFW/A-MFW/A-HFW/A le custodie e i coperchi sono in lamiera uniforme di alluminio o rame saldati tra loro elettricamente (TIG) con uno spessore tale da poter tollerare forzature meccaniche e sollecitazioni elettriche.  
Gli spessori e l'elasticità dei contenitori sono rapportati alle eventuali variazioni di volume imposte dalle temperature di funzionamento. Per la movimentazione dei condensatori si deve far riferimento alle apposite maniglie saldate sulla cassa secondo le richieste del Cliente.

- **HEAVY-FOIL**

The not self-healing foil is defined **HEAVY** because to the polypropylene dielectric two aluminium foils of high purity are linked; their thickness is strictly conditioned by the very high current and reactive power values of the service.

### IMPREGNANT

- **RESIN**

It's used only for metallized foil capacitors and it allows to "close" with polyurethan resin all capacitors windings securing the filling and the protection from exterior.

- **IMPREGNANT OIL**

It's a synthetic oil, biodegradable, no toxic with excellent electric performances, very high break-down values and a very low dissipation factor. It's used only for heavy foil capacitors.

**This fluid not contains PCB.**

### CASES

- For HFCU series capacitors, used cases are in copper.
- For LFW/A-MFW/A-HFW/A series capacitors cases and covers are both in aluminium or in copper with TIG weldings. Thicknesses of cases and covers has been valued to tolerate mechanical forcings and electrical stress. Thicknesses and elasticity of cases are in line with possible changes of volume forced by working temperature. To move capacitors it's necessary to use the appropriate handles soldered to the case as Customer asks.





# CONDENSATORI PER FORNI A INDUZIONE

## INDUCTION HEATING CAPACITORS

### CAPACITORS IN TOUCH WITH YOUR NEEDS



#### RAFFREDDAMENTO

Tre sono i sistemi di raffreddamento riscontrabili nei prodotti della società INCO:

- **RAFFREDDAMENTO NATURALE**

Questo tipo di raffreddamento è effettuato tramite una circolazione naturale dell'aria che nell'ambiente operativo non deve eccedere i 40 °C : tale rilievo deve essere effettuato tra due condensatori ad un'altezza dal basso pari a 2/3 dell'altezza del condensatore stesso.

- **RAFFREDDAMENTO FORZATO DELL' OLIO IMPREGNANTE**

Questo tipo di servizio è ottenuto con una circolazione forzata di acqua attraverso una o due serpentine disconnesse dalla parte capacitiva e posizionate sui lati piccoli della custodia. Tale tipo di raffreddamento è utilizzato quando il servizio richiesto è strettamente condizionato da costo, spazio e tipo di utilizzo che può essere anche parzializzato per elevati valori di corrente e frequenza.

- **RAFFREDDAMENTO FORZATO DELLA PARTE ATTIVA**

Questo tipo di servizio è ottenuto con una circolazione forzata di acqua attraverso una o più serpentine di raffreddamento strettamente connesse alle armature degli avvolgimenti in modo da poter limitare la temperatura interna del condensatore in servizio a valori calcolati a progetto. Per l'ottimizzazione delle connessioni interne sono utilizzate speciali tecniche che garantiscono qualitativamente i collegamenti elettrici, la conduttività termica, la tenuta meccanica tra le armature e il sistema di raffreddamento in rame.

#### COOLING SYSTEM

INCO proposes three cooling systems:

- **NATURAL COOLING SYSTEM**

*This kind of cooling system is carried out with a natural air circulation that in the ambient must not exceed 40 °C: this measurement must be done between two capacitors at a bottom-up height of 2/3 of the height of capacitor itself.*

- **FORCED COOLING OF IMPREGNANT OIL**

*This tipe of service is obtained with forced cooling water in one or two serpentes not connected to capacitor windings and placed in correspondance of the short sides of the case. This kind of cooling is used when the required service is tightly conditioned by cost, dimension and type of use that may be choked for high values of current and frequency.*

- **FORCED COOLING OF ACTIVE PART.**

*This service is obtained with a forced circulation of water in one or more cooling serpentes tightly connected to windings plates to limit internal temperature of capacitors in service to values defined by design. To obtimize internal connections, special technics are used that assure connections quality, thermal conductivity, mechanic seal among internal plates and the cooling system in copper.*





**CONDENSATORI PER FORNI A INDUZIONE**

**INDUCTION HEATING CAPACITORS**

**CAPACITORS IN TOUCH WITH YOUR NEEDS**



**RAFFREDDAMENTO NATURALE**  
**NATURAL COOLING**

**CONDENSATORI STATICI CON RAFFREDDAMENTO NATURALE**  
**NATURAL COOLING STATIC CAPACITORS**

**CARATTERISTICHE GENERALI DI PRODOTTO**  
*PRODUCT FEATURES*

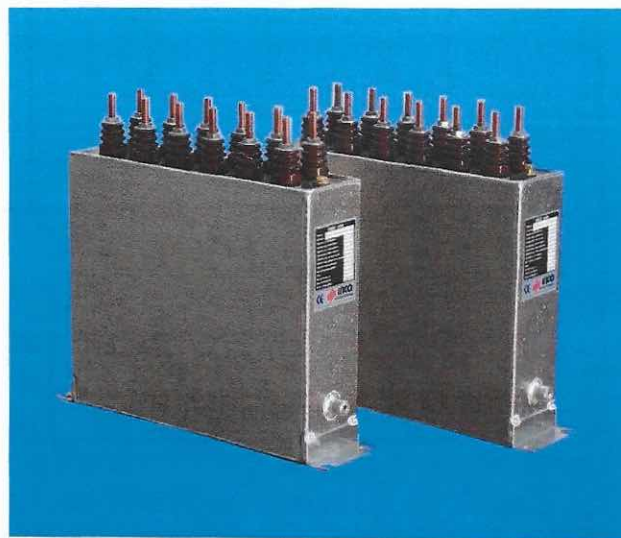
<b>SERIE</b> <i>SERIES</i>	<b>I-LFA – I-MFA</b>
<b>ISOLATORI</b> <i>INSULATORS</i>	<b>M12</b>
<b>N. ISOLATORI</b> <i>N. INSULATORS</i>	<b>Min. 2+2 ; max. 6+6</b>
<b>CUSTODIA</b> <i>CASE</i>	<b>ALLUMINIO</b> <i>ALUMINIUM</i>
<b>ESECUZIONI POSSIBILI</b> <i>POSSIBLE EXECUTIONS</i>	<b>Dead case</b>
<b>SE RICHiesto</b> <i>IF REQUIRED</i>	<b>PRESSOSTATO</b> <i>PRESSURE SWITCH</i>
<b>OLIO IMPREGNANTE</b> <i>IMPREGNANT OIL</i>	<b>OLIO SINTETICO, BIODEGRADABILE NON TOSSICO. NON CONTIENE PCB</b>  <i>SYNTHETIC OIL, BIODEGRADABLE, NO TOXIC IT DOES NOT CONTAIN PCB</i>

**CARATTERISTICHE DI PROCESSO**  
***PRODUCTION FEATURES***

- Prova di ermeticità ( 70 °C x 10 h ).  
*Sealing test (70 °C x 10 h)*
- Prova di tensione tra i terminali:  
**2xU<sub>N</sub> x 10s**  
*Voltage test between terminals:  
2xU<sub>N</sub>x10s*
- Prova di tensione tra i terminali (dead case) e la custodia 2,15xU<sub>N</sub>x10s minimo 2 kV<sub>AC</sub>  
*AC voltage test between terminals (dead case) and case*
- Misura di capacità: 1,5 V<sub>AC</sub> x 5 s  
*Capacitance test: 1,5 V<sub>AC</sub> x 5 s*
- Misura di tgδ: 1 kHz x 5 s  
*Loss angle tangent test: 1 KHz x 5 s*

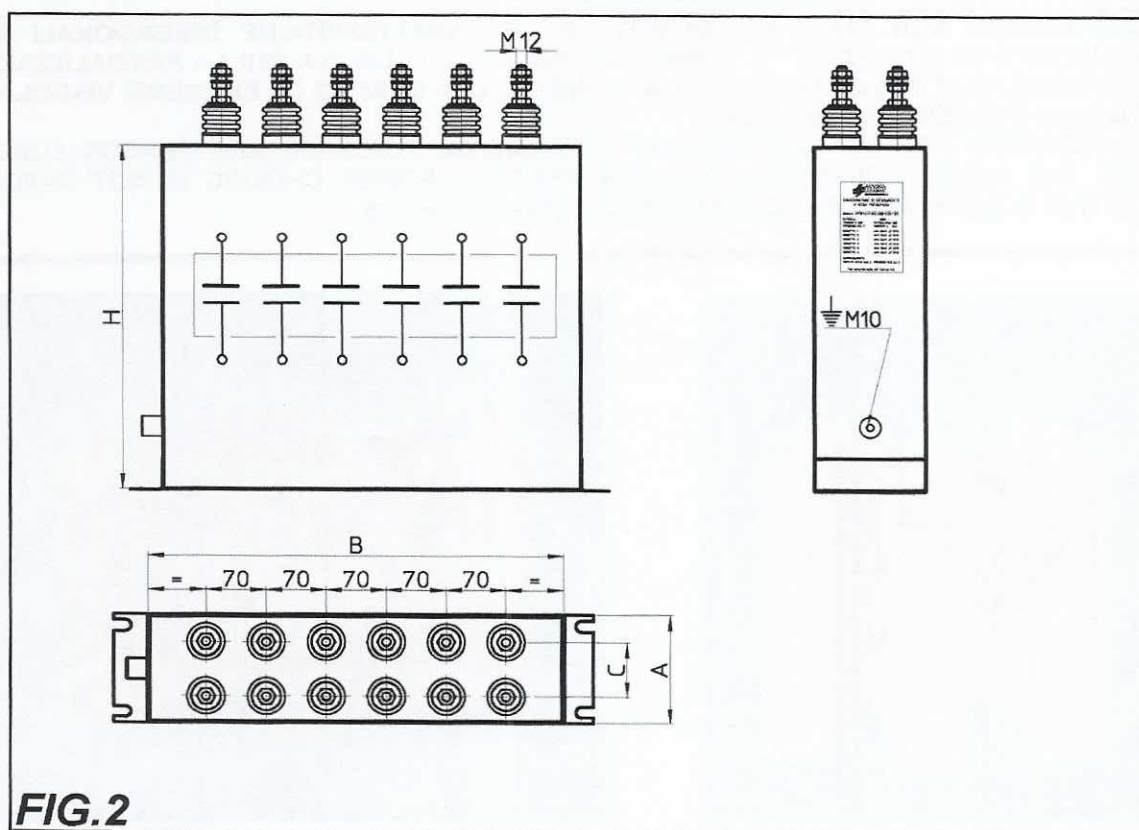
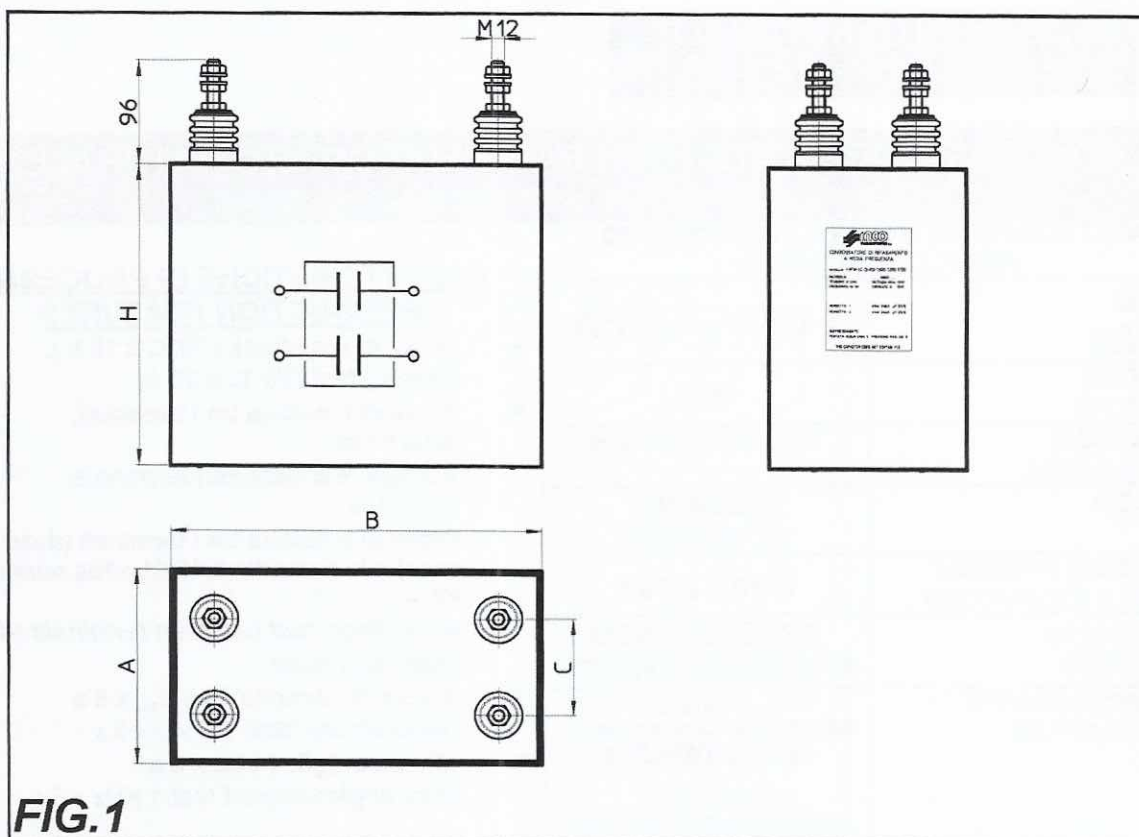
**I VALORI INDICATI NON SONO VINCOLANTI E LE CARATTERISTICHE DIMENSIONALI SONO PERSONALIZZATE SU RICHIESTA. IL NUMERO DI ISOLATORI DI USCITA PER LA PARZIALIZZAZIONE DELLA POTENZA REATTIVA CAPACITIVA NON E' INDICATO IN QUANTO DA RITENERSI VINCOLATO E DEFINITO DALLE NECESSITA' DEI CLIENTI.**

*VALUES INDICATED ARE NOT BINDING AND DIMENSIONAL FEATURES ARE PERSONALIZED ON REQUEST. THE NUMBER OF INSULATORS FOR REACTIVE POWER CHOKING IS NOT INDICATED BECAUSE IT IS CONSTRAINED AND DEFINED BY CUSTOMERS NEEDS.*





**CONDENSATORI PER FORNI A INDUZIONE**  
**INDUCTION HEATING CAPACITORS**  
**CAPACITORS IN TOUCH WITH YOUR NEEDS**



**CONDENSATORI STATICI CON RAFFREDDAMENTO NATURALE**  
**NATURAL COOLING STATIC CAPACITORS**

CARATTERISTICHE DI PRODOTTO PRODUCT FEATURES			CONDIZIONI DI MONTAGGIO ASSEMBLING CONDITIONS	
<b>SIGLA DI RIFERIMENTO</b> IDENTIFICATION	<b>I-LFA-</b>	<b>I-MFA-</b>	<ul style="list-style-type: none"> <li>Le unità capacitive possono essere installate in posizione verticale o orizzontale con l'appoggio su un lato stretto. <i>Capacitive units may be installed in vertical position or in horizontal positions but only on a small side of the rectangle.</i></li> <li>Distanza tra due unità : <math>\geq 50</math> mm. <i>Distance between two units: <math>\geq 50</math> mm.</i></li> <li>Se i rack sono montati su più livelli il grado di temperatura deve essere equilibrato in corrispondenza di ognuno di essi. <i>If racks are installed on more than one level, temperature must be balanced among capacitors.</i></li> <li>Per il serraggio dei dadi e delle rondelle verificare fig. 11. <i>For the tightening of nuts and washers check Fig.11</i></li> </ul>	
<b>RANGE DI TENSIONE</b> VOLTAGE RANGE	$\leq 3000$ V	$\leq 1500$ V		
<b>FREQUENZA</b> FREQUENCY	50 / 60 Hz	$f \leq 24$ kHz		
<b>CUSTODIA</b> CASE	ALLUMINIO ALLUMINIUM	ALLUMINIO ALLUMINIUM		
<b>TEMPERATURA AMBIENTE</b> AMBIENT TEMPERATURE	- 25 +45 °C	- 25 +45 °C		
<b>RAFFREDDAMENTO</b> COOLING	NATURALE NATURAL	NATURALE NATURAL		
<b>CONNESSIONE ISOLATORI</b> INSULATOR CONNECTION	max 2+2	max 6+6		
<b>ESECUZIONE</b> EXECUTION	Dead case	Dead case		
<b>CONNESSIONI</b> CONNECTIONS	M12	M12		
<b>DIS. DI RIFERIMENTO</b> DRAWINGS	Fig. 2	Fig. 3	<b>SETTORI INTERESSATI</b> Forni fusori a CANALE, con PIGIATA, per METALLI (acciaio, rame, ottone, zinco, alluminio) <i>INTERESTED SECTORS</i> SLOT FURNACES, with LINING and METALS: steel, copper, brass, zinc, aluminium	

**I-LFA-**

f <sub>N</sub> Hz	U <sub>N</sub> V	Q <sub>N</sub> kvar	I <sub>N</sub> A	C <sub>N</sub> µF	DIMENSIONI DIMENSIONS mm			PESO WEIGHT kg
					A	B	H	
50	500	100	200	1274	184	343	1000	~ 88
	1000		350	1115				
	1500		233	495				
	2000		175	279				
	2500		140	178				
	3000		117	124				

**I-MFA-**

9600	500	222	443	14,70	<b>DIMENSIONI VINCOLATE ALLE NECESSITA' DEL CLIENTE</b> <i>DIMENSIONS ARE BOUND BY CUSTOMERS NEEDS</i>
9600	500	300	600	19,90	
10000	600	360	599	15,90	
12000	1000	360	360	4,70	
20000	1000	360	360	2,87	
24000	1000	360	360	2,39	





# CONDENSATORI PER FORNI A INDUZIONE INDUCTION HEATING CAPACITORS CAPACITORS IN TOUCH WITH YOUR NEEDS



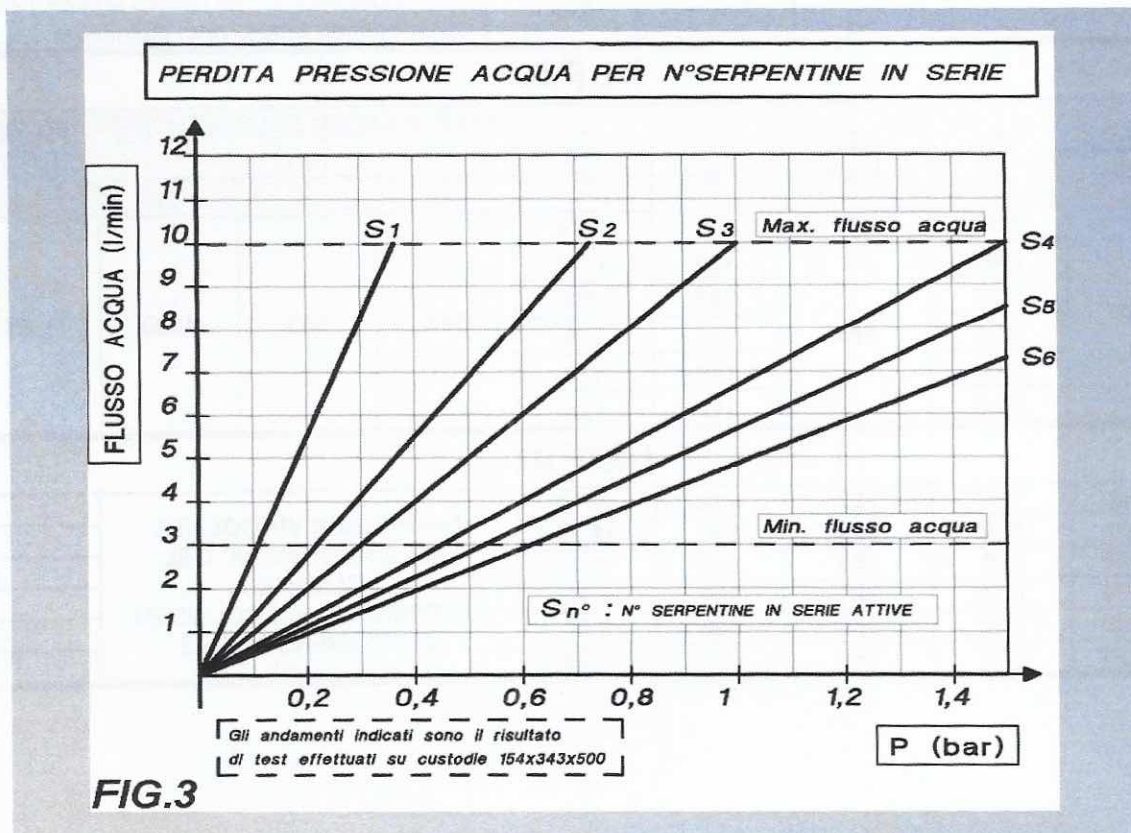
## RAFFREDDAMENTO CON ACQUA WATER COOLING

### MODALITA' DI RAFFREDDAMENTO

In presenza di più condensatori collegati in parallelo l'uscita dell'acqua da una serpentina può essere collegata all'ingresso nella serpentina di un condensatore affiancato con l'obiettivo di ottimizzare il sistema: il numero massimo di serpentine collegabili in serie è 6. Passando con un collegamento serie da una serpentina alla seguente si ha una perdita di pressione che è indicata nel grafico seguente fino alla connessione massima di 6 condensatori. Il collegamento tra il terminale di uscita di una serpentina e il terminale di ingresso della successiva, se connesse allo stesso polo elettrico, non impone l'utilizzo di determinate lunghezza del tubo per il trasferimento dell'acqua di raffreddamento, in caso contrario impone l'utilizzo di una lunghezza di tubo  $\geq 500$  mm.

### COOLING METHOD

If there are more parallel connected capacitors, the outlet water from a serpentine may be turned to the entering connection of the serpentine of another flanked capacitor, with the purpose of optimize the system: the maximum number of series connected serpentine is 6. Moving with a series connection from a serpentine to another one there is a loss of water pressure that's indicated in the following graph with a maximum connection of 6 capacitors. The connection between the outlet connection of a serpentine and the inlet the following one, if connected to the same electric pole, does't impose the use of particular tube lengths to move the cooling water, in an opposite situation the tube length must be  $\geq 500$  mm.





**CONDENSATORI PER FORNI A INDUZIONE**  
**INDUCTION HEATING CAPACITORS**  
**CAPACITORS IN TOUCH WITH YOUR NEEDS**



**CONDIZIONI FONDAMENTALI DI UTILIZZO**  
**USE FONDAMENTAL CONDITIONS**

<b>TEMPERATURA AMBIENTE</b> <i>AMBIENT TEMPERATURE</i>	Temperatura minima <i>MINIMUM TEMPERATURE</i>	°C	1
	Temperatura massima <i>MAXIMUM TEMPERATURE</i>	°C	50
<b>TEMPERATURA DELL'ACQUA</b> <i>WATER TEMPERATURE</i>	Temperatura dell'acqua in entrata <i>MAXIMUM ENTERING WATER TEMPERATURE</i>	°C	≤ 30
	Temperatura dell'acqua in uscita <i>MAXIMUM OUTLET WATER TEMPERATURE</i>	°C	≤ 40
<b>PORTATA D'ACQUA</b> <i>WATER FLOW RATE</i>	Minima portata d'acqua <i>MINIMUM WATER FLOW RATE</i>	l/min.	3
	Massima portata d'acqua <i>MAXIMUM WATER FLOW RATE</i>	l/min.	10
<b>PRESSIONE</b> <i>PRESSURE</i>	Massima pressione dell'acqua <i>MAXIMUM WATER PRESSURE</i>	bar	8

**LE VERIFICHE DI SERVIZIO E TEMPERATURA DEBONO ESSERE ATTUATE NON MENO DI 10 ORE DALLA MESSA IN FUNZIONE DELL'IMPIANTO.**  
**SERVICE AND TEMPERATURE CONTROLS MUST BE EFFECTED NOT LESS THAN 10 HOURS FROM WORKING STARTING OF THE PLANT**





# CONDENSATORI PER FORNI A INDUZIONE

## INDUCTION HEATING CAPACITORS

### CAPACITORS IN TOUCH WITH YOUR NEEDS



#### **IMPORTANTE !**

- Assicurarsi della presenza del flusso d'acqua nelle serpentine prima della messa in funzione dell'impianto in quanto, se i circuiti di raffreddamento non sono sistematicamente verificati, eventuali incrostazioni ed occlusioni possono opporsi a un libero flusso dell'acqua di raffreddamento.
- Assicurarsi che l'acqua nel circuito di raffreddamento non ghiacci durante i tempi di inattività; se non si è certi eliminare la presenza di acqua con aria compressa. In casi a rischio si consiglia l'utilizzo:
  - **DEIONIZZATORE** : dispositivo nel quale circola acqua demineralizzata dello scambiatore di calore provvedendo ad un trattamento ottimale della stessa ed evitando fenomeni di elettrolisi con conseguenti corrosioni.
  - **ANTIGELO** : dispositivo posizionato in modo da provvedere al mantenimento di una temperatura idonea che eviti il congelamento.
- L'acqua nelle serpentine deve essere rimossa anche in caso di stoccaggio o trasporto dell'impianto o dei condensatori.
- Il collegamento ai terminali delle serpentine e agli isolatori è opportuno sia flessibile per evitare sollecitazioni meccaniche.

E' estremamente dannoso movimentare i condensatori facendo presa sulle serpentine o sugli isolatori.

#### **NORME DI RIFERIMENTO**

- IEC PUBLICATION 110  
VDE 0560 Teil 9/10.70

#### **IMPORTANT !**

- *Be sure of the presence of water flow in serepntines before the switching on of plant because if the cooling systems are not verified, probable limestone deposits and consequent occlusions may be in opposition to a free flowing of cooling water.*
- *Be sure that water in cooling system cycuit does'nt ice during an inactivity period: if you are not sure try to eliminate the presence of water with compressed air. In case of risk we advice the use of:*
  - **DEIONIZER** : device where the demineralized water of the heat exchanger keeps moving realizing an optimum treatment of water itself and evoiding the phenomenons of electrolysis with corrosions.
  - **ANTIFREEZE** : device located to provide the holding of a suitable temperature to evoid the water freezing
- *The water in the serpntines must be removed also in case of stocking or transport of plant or capacitors.*
- *The connection to serpntines outputs must be flexible to evoid mechanical load stress.*

*It's very harmful to move capacitors using serpntines or insulators as knobs.*

#### **DATUM STANDARDS**

- IEC PUBLICATION 110  
VDE 0560 Teil 9/10.70





# CONDENSATORI PER FORNI A INDUZIONE

## INDUCTION HEATING CAPACITORS

### CAPACITORS IN TOUCH WITH YOUR NEEDS



#### CONDENSATORI STATICI RAFFREDDATI AD ACQUA PER BASSA, MEDIA E ALTA FREQUENZA

#### WATER COOLING STATIC CAPACITORS FOR LOW, MEDIUM AND HIGH FREQUENCY

CARATTERISTICHE GENERALI DI PRODOTTO PRODUCT FEATURES		SERIE SERIES	
<b>TIPO DI CONNESSIONE</b> CONNECTION TYPE	PARZIALIZZATA <i>CHOKED</i> MISTA <i>MIXED</i> GLOBALE <i>GLOBAL</i>	<b>I-LFW</b>	LAMINAZIONE <i>HOT ROLLING</i> FORGIATURA <i>INDUCTION FORGING</i> STAMPAGGIO <i>HOT PRESSING</i>
<b>ISOLATORI</b> INSULATORS	<b>M12</b>	<b>I-MFW</b>	SALDATURA <i>WELDING</i> TEMPRA TOTALE <i>TOTAL HARDENING</i> FUSIONE DEI PREZIOSI <i>GOLD SMELTING</i> LAVORAZIONE A CALDO <i>HOT TREATMENT</i>
<b>N. ISOLATORI</b> N. INSULATORS	<b>Max. 8</b>	<b>I-HFW</b>	SALDATURA DEI TUBI <i>WELDING PIPES</i> TRATTAMENTO ACCIAIO <i>STEEL TREATMENT</i> RISCALDO IN CONTINUO <i>CONTINUOUS HEATING</i>
<b>PRESE ACQUA</b> WATER CONNECTIONS	<b>M20</b>	<b>RAFFREDDAMENTO FORZATO DIRETTO CON ACQUA</b>  <b>DIRECT FORCED WATER COOLING</b>  <input type="checkbox"/> <b>N. SERPENTINE</b> N SERPENTINES <b>≤ 4</b>  <input type="checkbox"/> <b>TEMPERATURA MASSIMA ACQUA IN ENTRATA</b> MAXIMUM TEMPERATURE OF THE ENTERING WATER. <b>30 °C</b>  <input type="checkbox"/> <b>TEMPERATURA MASSIMA ACQUA IN USCITA</b> MAXIMUM TEMPERATURE OF THE COMING OUT WATER. <b>40 °C</b>  <input type="checkbox"/> <b>MINIMA PORTATA DI ACQUA</b> MINIMUM WATER FLOW <b>3 l/min.</b>  <input type="checkbox"/> <b>MASSIMA PORTATA D'ACQUA</b> MAXIMUM WATER FLOW <b>10 l/min.</b>  <input type="checkbox"/> <b>MASSIMA PRESSIONE</b> MAXIMUM PRESSURE <b>8 bar</b>  <input type="checkbox"/> <b>CONNESSIONI SERPENTINE</b> SERPENTINES CONNECTIONS <b>M20</b>	
<b>CUSTODIA</b> CASE	ALLUMINIO <i>ALUMINIUM</i> RAME <i>COPPER</i>		
<b>ESECUZIONI POSSIBILI</b> POSSIBLE EXECUTIONS	<b>Live case</b> <b>Dead case</b>		
<b>SE RICHIESTO</b> IF REQUIRED	<b>PRESSOSTATO</b> <i>PRESSURE SWITCH</i>		
<b>OLIO IMPREGNANTE</b> IMPREGNANT OIL	OLIO SINTETICO, BIODEGRADABILE NON TOSSICO. <b>NON CONTIENE PCB</b>  SYNTHETIC OIL, BIODEGRADABLE, NO TOXIC <b>IT DOES NOT CONTAIN PCB</b>		
<b>CARATTERISTICHE DI PROCESSO</b> <b>PRODUCTION FEATURES</b>			
<ul style="list-style-type: none"> <li>▪ Prova di ermeticità ( 70 °C x 10 h ). <i>Sealing test (70 °C x 10 h)</i></li> <li>▪ Prova di tensione tra i terminali: <b>2xU<sub>N</sub> x 10s</b> <i>Voltage test between terminals: 2xU<sub>N</sub>x10s</i></li> <li>▪ Prova di tensione tra i terminali (dead case) e la custodia <b>2,15xU<sub>N</sub>x10s</b> minimo <b>2 kV<sub>AC</sub></b> <i>AC voltage test between terminals (dead case) and case</i></li> <li>▪ Misura di capacità: <b>1,5 V<sub>AC</sub> x 5 s</b> <i>Capacitance test: 1,5 V<sub>AC</sub> x 5 s</i></li> <li>▪ Misura di tgδ: <b>1 KHz x 5 s</b> <i>Loss angle tangent test: 1 KHz x 5 s</i></li> </ul>		<b>SISTEMA DI RAFFREDDAMENTO</b> <b>COOLING SYSTEM</b>	





**CONDENSATORI PER FORNI A INDUZIONE**  
**INDUCTION HEATING CAPACITORS**  
**CAPACITORS IN TOUCH WITH YOUR NEEDS**



**CONDENSATORI STATICI RAFFREDDATI AD ACQUA PER BASSA, MEDIA E ALTA FREQUENZA**  
**WATER COOLING STATIC CAPACITORS FOR LOW, MEDIUM AND HIGH FREQUENCY**

CARATTERISTICHE DI PRODOTTO <i>PRODUCT FEATURES</i>	<b>I-LFW</b>	<b>I-MFW</b>	<b>I-HFW</b>
RANGE DI TENSIONE <i>VOLTAGE RANGE</i>	≤ 3000 V	≤ 3000 V	≤ 3000 V
RANGE DI FREQUENZA <i>FREQUENCY RANGE</i>	f < 1000 Hz	1000 Hz ≤ f ≤ 24000 Hz	f > 24000 Hz
CUSTODIA <i>CASE</i>	ALLUMINIO <i>ALLUMINIUM</i>	ALLUMINIO <i>ALLUMINIUM</i>	ALLUMINIO <i>ALLUMINIUM</i>
TEMPERATURA AMBIENTE <i>AMBIENT TEMPERATURE</i>	1 °C .....50 °C	1 °C .....50 °C	1 °C .....50 °C
MAX. °C ACQUA IN USCITA <i>MAXIMUM OUTLET WATER TEMPERATURE</i>	40 °C	40 °C	40 °C

**I-LFW**

f <sub>N</sub> Hz	U <sub>N</sub> V	Q <sub>N</sub> kvar	I <sub>N</sub> A	C <sub>N</sub> µF	DIMENSIONI <i>DIMENSIONS</i> mm			Dis.	PESO <i>WEIGHT</i> kg
					A	B	H		
200	1600	1000	625	311	165	369	800	fig.4 fig.5 fig.11	73
300	1500	1275	851	301	165	369	800		46
400	1250	1200	961	306	165	369	800		42
500	1250	1472	1178	300	165	369	500		36
600	1450	1584	1093	200	165	369	500		
700	1450	1500	1033	162	165	369	500		
800	1450	1200	828	114	165	343	500		
900	1100	1350	1227	197	154	343	450		

**I-MFW**

2000	650	1200	1846	226,00	134	343	500	fig.4 fig.5 fig.6 fig.7 fig.8 fig.9 fig.11	34
3000	800	900	1125	74,60	104	343	330		18
4000	500	800	1601	127,40	134	343	330		23
5000	1250	1500	1200	30,55	134	343	215		15
6000	650	1000	1539	62,80	134	343	280		19
7000	1300	2000	1539	26,91	154	343	330		25
8000	1000	2000	2000	39,79	154	343	330		26
9000	900	2000	2222	43,66	154	343	550		44
10000	800	1200	1500	29,85	134	343	330		23
24000	600	500	833	9,21	104	343	215		12

**I-HFW**

25000	600	600		12,00	104	343	215	fig.10	12
30000	600	500		7,38					
35000	900	650	722	3,65					
40000	880	700		3,60					
45000	500	500		7,08					
50000	600	600		5,31					
60000	700	650	1000	3,79					
80000	700	650	929	2,64					
100000	600	600		2,65					





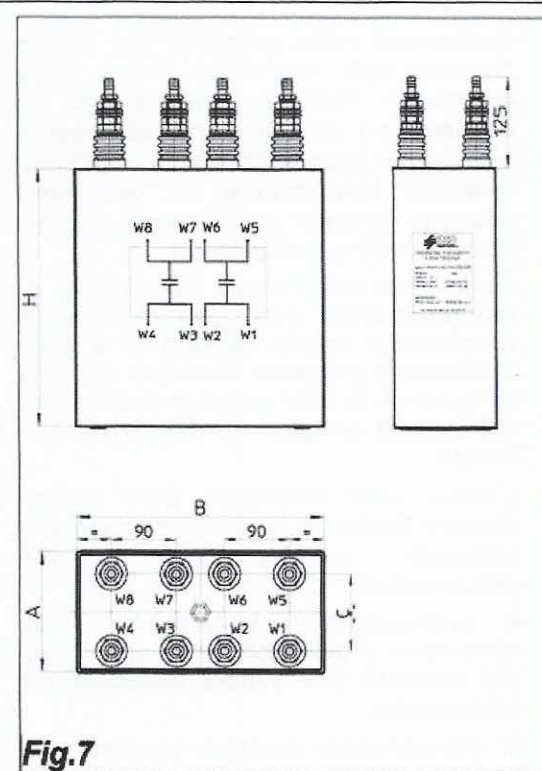
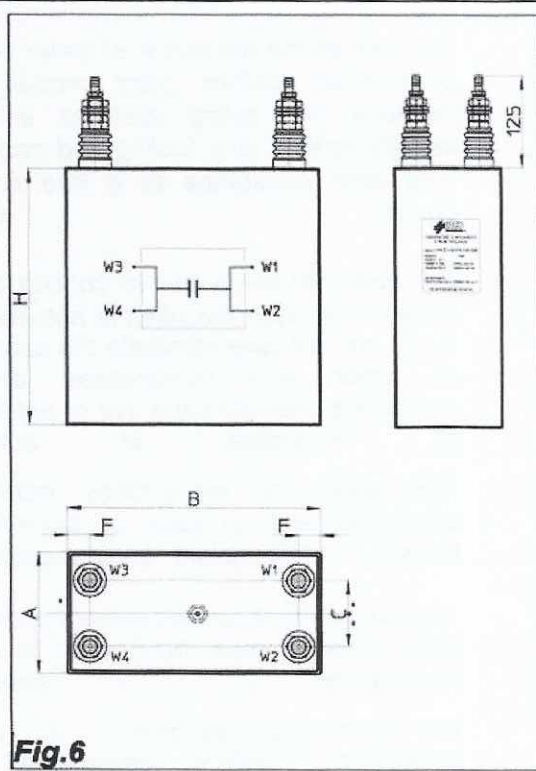
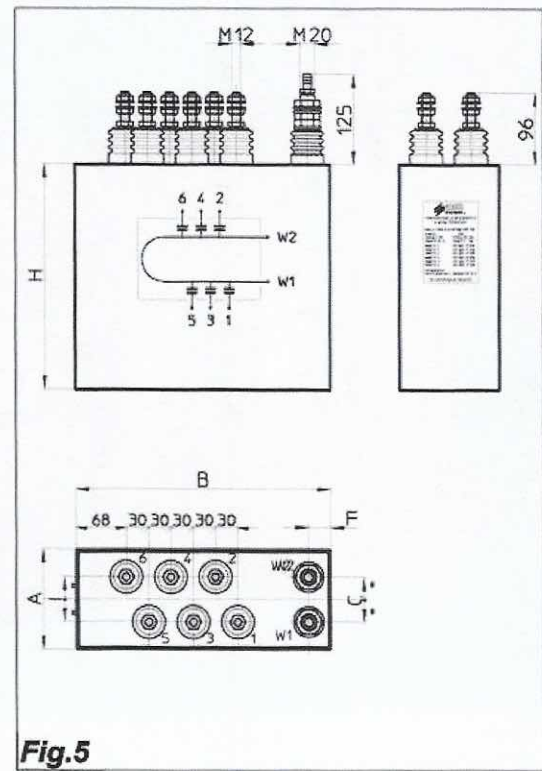
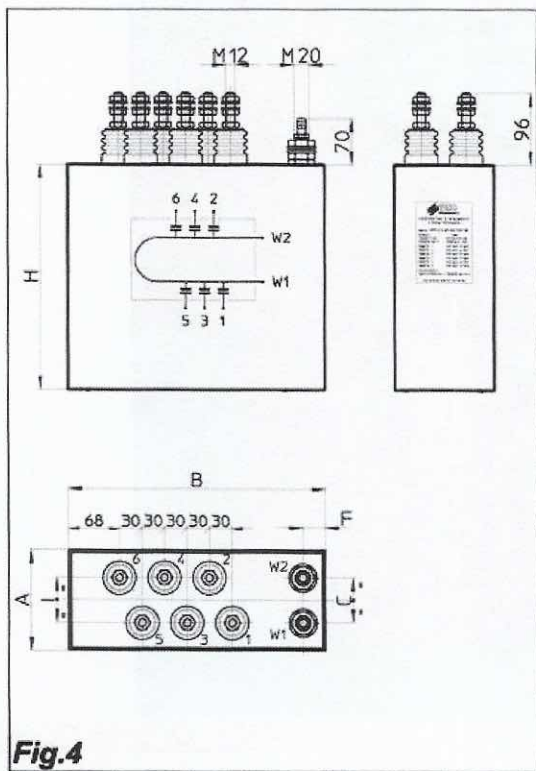
**CONDIZIONI E OPERAZIONI DI MONTAGGIO**

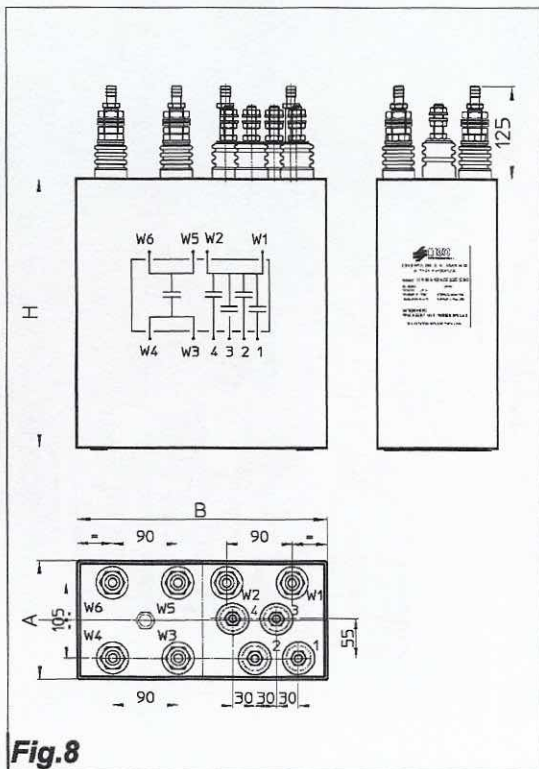
- Assicurarsi della presenza del flusso d'acqua nelle serpentine prima della messa in funzione dell'impianto in quanto, se i circuiti di raffreddamento non sono sistematicamente verificati, eventuali incrostazioni ed occlusioni possono opporsi a un libero flusso dell'acqua di raffreddamento.
- Assicurarsi che l'acqua nel circuito di raffreddamento non ghiacci quando l'impianto è fermo, se non si è certi eliminare la presenza di acqua con aria compressa: in casi a rischio si consiglia l'utilizzo di antigelo di protezione per l'acqua.
- L'acqua nelle serpentine deve essere rimossa anche in caso di stoccaggio o trasporto dell'impianto o dei condensatori.
- Il collegamento ai terminali delle serpentine e agli isolatori è opportuno sia flessibile per evitare sollecitazioni meccaniche.
- E' estremamente dannoso movimentare i condensatori facendo presa sulle serpentine o sugli isolatori.
- Per il serraggio dei dadi e delle rondelle verificare fig. 11.

**CONDITIONS AND OPERATIONS OF ASSEMBLING.**

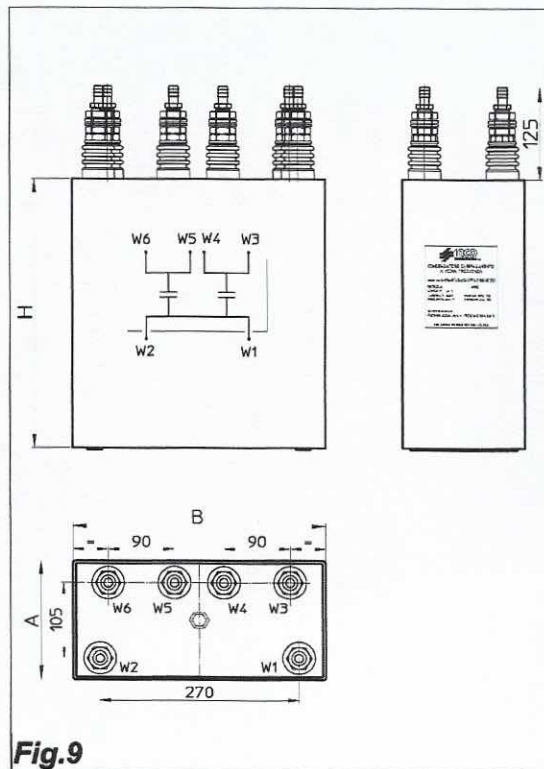
- *Be sure of the presence of water flow in serpentes before plant working on because, if cooling systems are not always verified, any fouling and occlusion may offer resistance to a free flow of cooling water.*
- *Be sure that the water in cooling circuit doesn't ice when the plant is not working, if you are not sure eliminate the presence of water with compressed air: in dangerous situations the use of antifreeze of protection is advised.*
- *The water of serpentes must be eliminated also in case of stocking or transport of the plant or of capacitors.*
- *The connections to serpentes terminals and insulators must be flexible to avoid mechanical stresses.*
- *It's extremely dangerous to move capacitors holdind serpentes or insulators.*
- *For the tightening of nuts and washers follow fig. 11.*



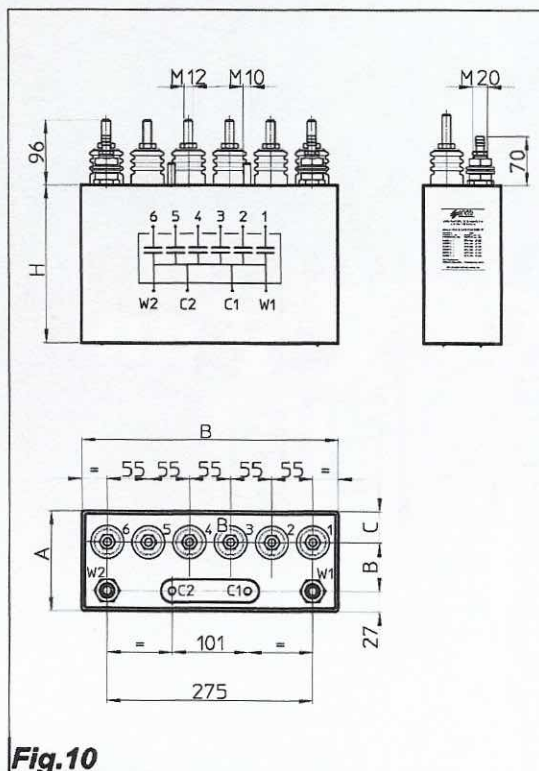




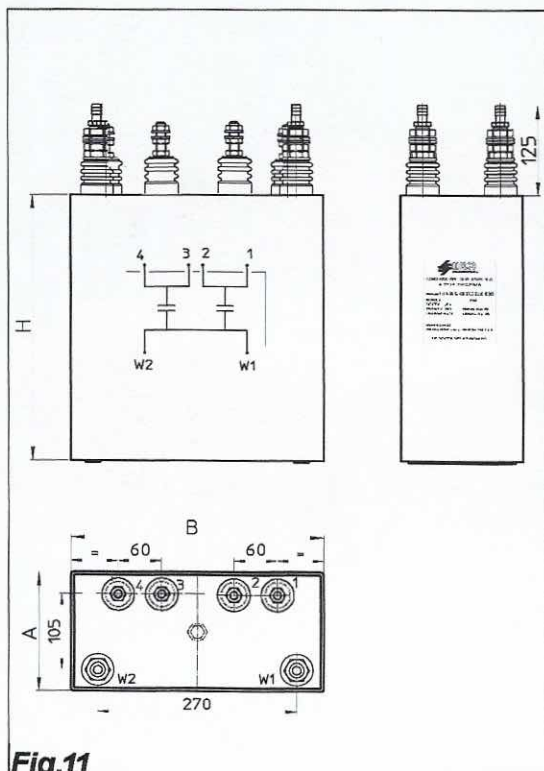
**Fig.8**



**Fig.9**



**Fig.10**

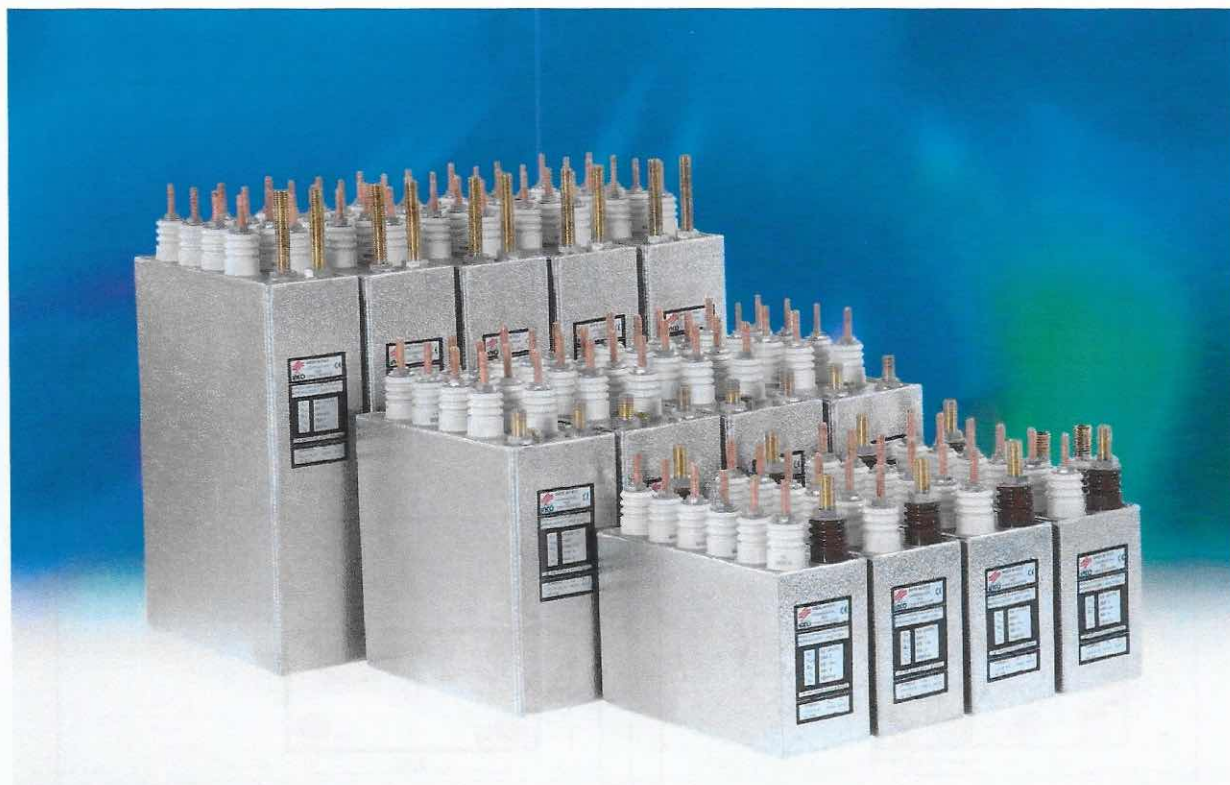


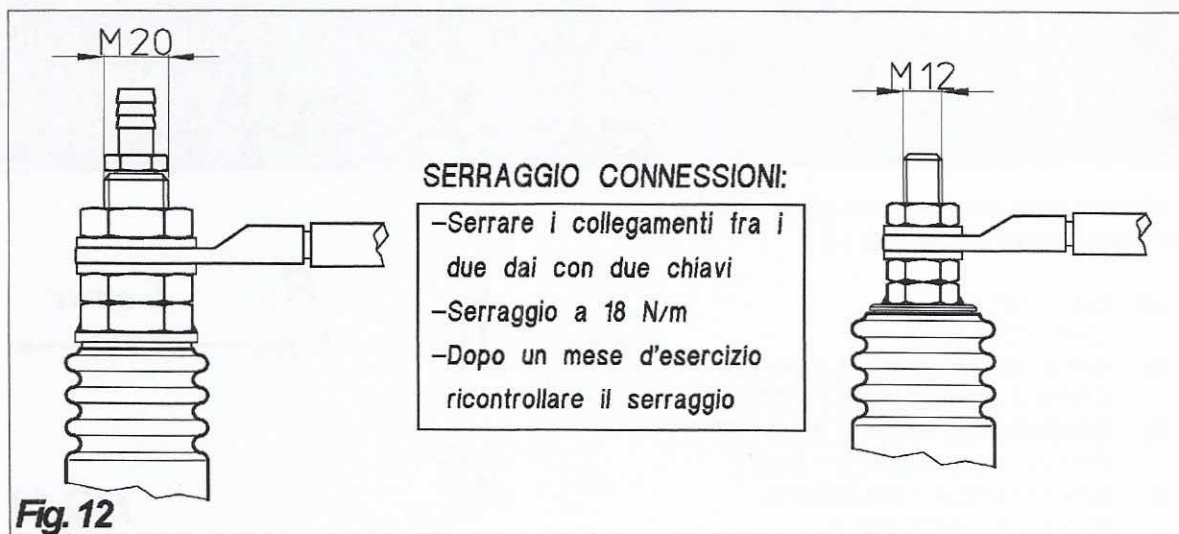
**Fig.11**





**CONDENSATORI PER FORNI A INDUZIONE**  
**INDUCTION HEATING CAPACITORS**  
**CAPACITORS IN TOUCH WITH YOUR NEEDS**







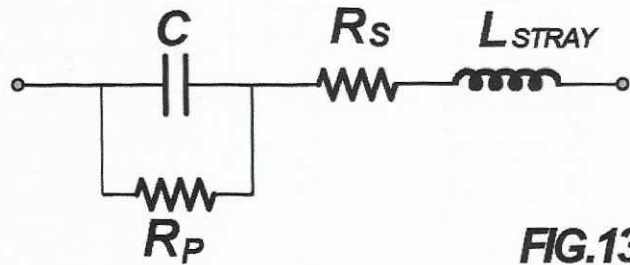
**CONDENSATORI PER FORNI A INDUZIONE**  
**INDUCTION HEATING CAPACITORS**  
**CAPACITORS IN TOUCH WITH YOUR NEEDS**



**HFAL - HFCU** CONDENSATORI STATICI PER ALTA FREQUENZA E BASSA INDUTTANZA CON RAFFREDDAMENTO IN ARIA, DI CONTATTO, DIRETTO E ABBINATO.  
 HFAL - HFCU STATIC CAPACITORS FOR HIGH FREQUENCY AND LOW INDUCTANCE WITH AIR COOLING, CONTACT COOLING, DIRECT COOLING AND COUPLED COOLING.

Circuito equivalente del condensatore FIG.13.  
 Capacitor's equivalent circuit FIG.13.

C	μF	CAPACITA'
		CAPACITANCE
R <sub>S</sub>	Ω	IMPEDEZA SERIE ( ESR )
		SERIES IMPEDENCE ( ESR )
R <sub>P</sub>	Ω	IMPEDEZA PARALLELO ( EPR )
		PARALLEL IMPEDENCE ( ESR )
L <sub>STRAY</sub>	H	INDUTTANZA PARASSITA
		STRAY INDUCTANCE



**FIG.13**

Le componenti capacitive e induttive dell'impedenza contribuiscono al valore complessivo della reattanza e non possono nella realtà essere distinte l'una dall'altra.

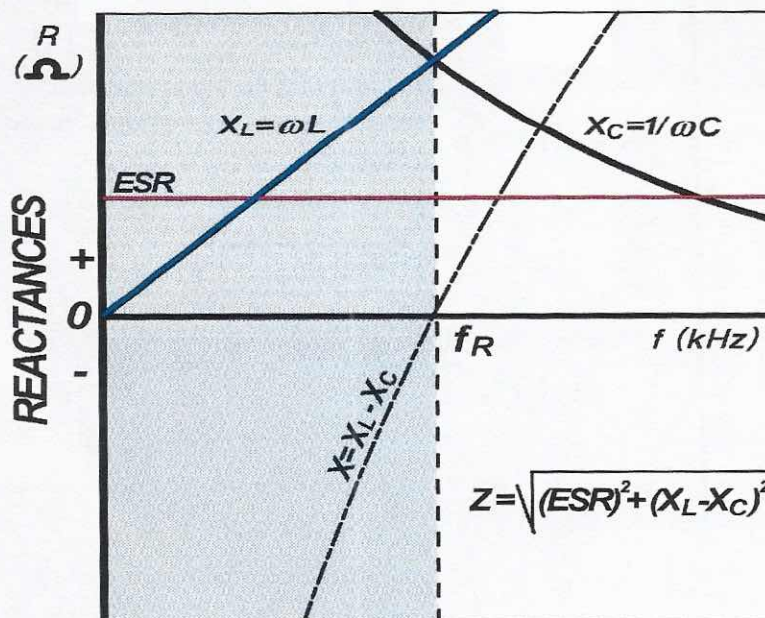
*The capacitive and inductive components of the impedance contribute to the total value of the reactance and in the reality can not be distinguished one from the other.*

**R<sub>P</sub> ( EPR )** : rappresenta la R interna del dielettrico che idealmente deve essere infinita, quindi a livello di progetto la corrente di fuga può essere considerata nulla.

*R<sub>P</sub> ( EPR ) : indicates the internal dielectric R that ideally must be infinite, so in the project the sneak current may be considered null.*

**L<sub>PARASSITA</sub>** :ponendo f = frequenza di utilizzo, è necessario che sia f<sub>R</sub> >> f per far sì che il condensatore non abbia una elevata componente induttiva parassita FIG.14.

*L<sub>STRAY</sub> : considering f = use frequency, it is very important that f<sub>R</sub> >> f so the capacitor has not a very high parassitic current component.*



**FIG. 14**





**CONDENSATORI PER FORNI A INDUZIONE**  
**INDUCTION HEATING CAPACITORS**  
**CAPACITORS IN TOUCH WITH YOUR NEEDS**



**DIELETTRICO**  
**POLIPROPILENE:**  
**“METALIZED AND UNMETALIZED”**

**ARMATURE**

Le armature dei condensatori della serie HFCU possono essere **“metalized + heavy foil”** o **heavy foil** : la scelta viene effettuata a livello di progetto con lo scopo di porre un limite alle alte temperature generate dalle altissime correnti circolanti e cercando di evitare al massimo così i problemi di **“self-healing”** che, se innescato, può generare continue diminuzioni di capacità ed elevatissimi picchi di corrente con limitazioni alla durata di vita del prodotto ed eventuali danni al sistema globale . Solamente una giusta scelta delle armature (sezione: mm<sup>2</sup>) permette il controllo della temperatura all'interno del condensatore con un conseguente prolungamento di vita del dielettrico e quindi del condensatore stesso.

**TERMINALI DI CONNESSIONI**  
M10xL = 15 mm

**ESECUZIONE**  
LIVE CASE

**DIELECTRIC**  
**POLYPROPYLENE:**  
**“METALIZED AND UNMETALIZED”**

**FOILS**

Series HFCU foils may be **“metalized + heavy foil”** or **heavy foil + heavy foil**: this choice is carried out at planning level with the purpose of restricting the high temperatures created by very high currents and looking for avoiding **“self-healing”** problems, that, if triggered off, may create continuous losses of capacitance and very high current peaks limiting product life and creating problems to the global system. Only a right foils choice (section: mm<sup>2</sup>) allow the temperature control in the internal part of capacitor with a consequent life prolongation of dielectric and so of the capacitor itself.

**CONNECTION TERMINALS**  
M10xL = 15 mm

**EXECUTION**  
LIVE CASE





# CONDENSATORI PER FORNI A INDUZIONE

## INDUCTION HEATING CAPACITORS

### CAPACITORS IN TOUCH WITH YOUR NEEDS



#### CARATTERISTICHE GENERALI DI PROCESSO

- Prova di stabilizzazione termica:  
60 °C x 10 h.
- Prova di tensione tra i terminali:  
 $U_{AC} = 1,5 U_N \times 10s$
- Misura di capacità:  
1,5  $V_{AC} \times 5 s$
- Misura di tg  $\delta$ :  
1 kHz x 5 s

#### CARATTERISTICHE DI SERVIZIO

Questo prodotto è utilizzato nei forni di riscaldamento a induzione che operano con elevati valori di frequenza e quindi necessitano di:

- Bassi valori di induttanza (L) che derivano dall'ottima sintesi dei collegamenti.
- Bassi valori di R deducibili dall'estrema brevità dei percorsi ohmici.
- Esigie perdite nel dielettrico.
- Diretto trasferimento del calore ai busbar a loro volta raffreddati con passaggio forzato di acqua in corrispondenza di entrambe le basi del cilindro capacitivo.

LA TEMPERATURA DELL'ACQUA IN USCITA IN CORRISPONDENZA DI ENTRAMBI I BUSBAR DI CONNESSIONE NON DEVE SUPERARE I **45 °C**.

E' MOLTO IMPORTANTE UN' ESTREMA OTTIMIZZAZIONE DEL CONTATTO DELLE TESTATE DI RAME DEI CONDENSATORI CON I RISPETTIVI BUSBAR.

PIU' UNITA' CAPACITIVE POSSONO ESSERE MONTATE IN SERIE O IN PARALLELO A SECONDA DELLE COMBINAZIONI TRA CAPACITA' E TENSIONI DESIDERATE

I VALORI INDICATI NON SONO VINCOLANTI E LE CARATTERISTICHE CAPACITIVE E DIMENSIONALI SONO PERSONALIZZATE SU RICHIESTA DEL CLIENTE.

#### GENERAL FEATURES OF PROCESS

- *Themic stabilisation test:*  
60 °C x 10 h.
- *Voltage test between terminals:*  
 $1,5 \times U_N \times 10s$
- *Capacitance test:*  
 $1,5 V_{AC} \times 5 s$
- *Loss angle tangent test:*  
1 kHz x 5 s

#### SERVICE FEATURES

*This product is used for induction heating furnaces operating with very high frequency values and cosequently they need of:*

- *Low inductance (L) values that are the result of an optimum synthesis of connections.*
- *Low values of resistance (R) that's the result of very short connections.*
- *Very low dielectric losses.*
- *Direct temperature transfer to the two busbars that are cooled with forced water near the two copper foils of capacitor.*

**THE TEMPERATURE OF COMING OUT WATER, IN CORRESPONDANCE OF BOTH CONNECTION BUSBARS, MUST NOT EXCEED 45 °C**

**IT'S VERY IMPORTANT AN EXTREME OPTIMIZATION OF CONTACT OF CAPACITORS COPPER CONNECTIONS WITH THE CORRESPONDANT BUSBAR.**

**MANY CAPACITANCE UNITS MAY BE SERIES / PARALLEL CONNECTED AFTER COSIDARIONS ABOUT REQUESTED CAPACITANCES AND VOLTAGES**

**INDICATED VALUES ARE NOT BINDING, CAPACITANCE VALUES AND DIMENSIONS MAY BE PERSONALIZED ON CUSTOMER REQUEST.**





# CONDENSATORI PER FORNI A INDUZIONE INDUCTION HEATING CAPACITORS CAPACITORS IN TOUCH WITH YOUR NEEDS



## METODI E TECNICHE DI RAFFREDDAMENTO

- **RAFFREDDAMENTO IN ARIA**  
Diretto trasferimento del calore ai busbar a loro volta raffreddati con la temperatura ambiente.
- **RAFFREDDAMENTO DI CONTATTO**  
Trasferimento diretto del calore ai busbar a loro volta raffreddati con passaggio forzato di acqua in corrispondenza di entrambe le basi del cilindro capacitivo.
- **RAFFREDDAMENTO DIRETTO**  
Raffreddamento diretto delle testate dei condensatori con passaggio forzato di acqua in corrispondenza di entrambe le basi delle unità capacitive.
- **RAFFREDDAMENTO ABBINATO**  
Raffreddamento di contatto abbinato al raffreddamento diretto.

## METHODS AND PROCEDURES OF COOLING

- **AIR COOLING**  
*Direct removal of heat to busbars that are ambient air cooled.*
- **CONTACT COOLING**  
*Direct removal of heat to busbars that are water cooled with a forced flow of water in correspondence of both copper foils.*
- **DIRECT COOLING**  
*Direct cooling of copper foils, that are directly connected to internal capacitor foils, with forced water for both the bases of capacitor.*
- **DOUBLE COOLING**  
*Contact and direct cooling at the same time.*





# CONDENSATORI PER FORNI A INDUZIONE

## INDUCTION HEATING CAPACITORS

### CAPACITORS IN TOUCH WITH YOUR NEEDS



#### CARATTERISTICHE HIGHLIGHTS

- **CON O SENZA RAFFREDDAMENTO DIRETTO**  
WITH OR WITHOUT DIRECT COOLING SYSTEM
- **SELF-HEALING / HEAVY FOIL**  
SELF-HEALING / HEAVY FOIL
- **INDUTTANZA PARASSITA  $\leq 5$  nH**  
STRAY INDUCTANCE  $\leq 5$  nH
- **FREQUENZE SI SERVIZIO  $\leq 900$  kHz**  
SERVICE FREQUENCY  $\leq 900$  kHz

**E' IMPORTANTE UN' ESTREMA OTTIMIZZAZIONE DEL CONTATTO DELLE TESTATE DEI CONDENS. CON I RISPETTIVI BUSBAR.**

IT'S IMPORTANT TO MOSTLY OPTIMIZE THE CONTACT OF OF CAPACITORS PLATES WITH CORRESPONDENT BUSBAR

**1 / 4 VITI DI FISSAGGIO DI OTTONE ( M10 x 15 ) PER OGNI ARMATURA**

1 / 4 FIXING BRASS STUDS ( M10 x 15 ) FOR EACH PLATE

#### CONDIZIONI D'USO FONDAMENTALI USE FUNDAMENTAL CONDITIONS

MIN. TEMPERAT. AMBIENTE MIN. AMBIENT TEMPERATURE	°C	1
MAX. TEMPERAT. AMBIENTE MAX. AMBIENT TEMPERATURE	°C	50
MAX. TEMP. ACQUA IN ENTRATA MAX. ENTERING WATER TEMPERATURE	°C	30
MAX. TEMP. ACQUA IN USCITA MAX EXIT WATER TEMPERATURE	°C	45
MIN. FLUSSO DELL'ACQUA MIN WATER FLOW RATE	l / min.	3
MAX. FLUSSO DELL'ACQUA MAX. WATER FLOW RATE	l / max.	10
MIN. PRESSIONE DELL'ACQUA MINIMUM WATER PRESSURE	BAR	3
MAX. PRESSIONE DELL'ACQUA MAXIMUM WATER PRESSURE	BAR	8

#### GRAFICI GRAPHICS



A vs kHz



V vs kHz



kvar vs kHz

VALORI CAPACITIVI DIVERSI SU RICHIESTA DIFFERENT CAPACITANCE VALUES ON REQUEST

#### DESIGNAZIONE DI TIPO TYPE DESIGNATION

HF.....-	AL	ARMATURE ESTERNE IN ALLUMINIO
	CU	ARMATURE ESTERNE IN RAME
HF.....-.....-	AA	ARMATURE INTERNE IN AL
	AZ	ARMATURE INTERNE IN AL+ZN
HF.....-.....-.....-	C	CIRCONFERENZA
	Q	QUADRATO
	Q2	QUADRATO DOPPIO FISSO
	P	RETTANGOLO
HF.....-.....-.....-.....-	C	RAFFREDDAMENTO DI CONTATTO
	D	RAFFREDDAMENTO DIRETTO



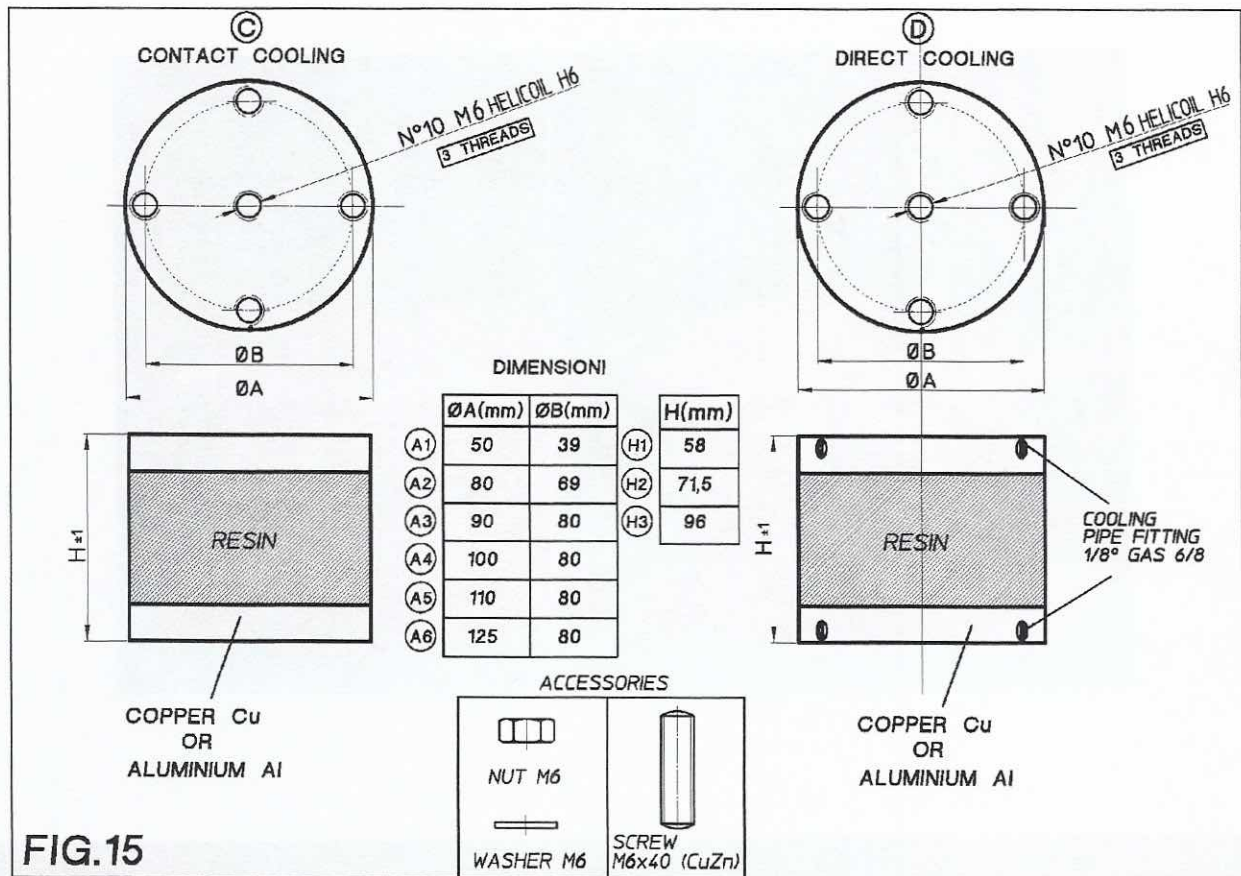


**CONDENSATORI PER FORNI A INDUZIONE**  
**INDUCTION HEATING CAPACITORS**  
**CAPACITORS IN TOUCH WITH YOUR NEEDS**





**CONDENSATORI PER FORNI A INDUZIONE**  
**INDUCTION HEATING CAPACITORS**  
**CAPACITORS IN TOUCH WITH YOUR NEEDS**



**FIG.15**





**CONDENSATORI PER FORNI A INDUZIONE**  
**INDUCTION HEATING CAPACITORS**  
**CAPACITORS IN TOUCH WITH YOUR NEEDS**



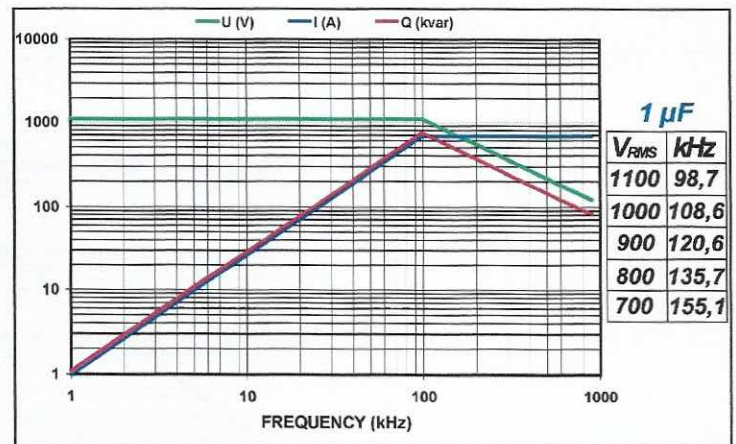
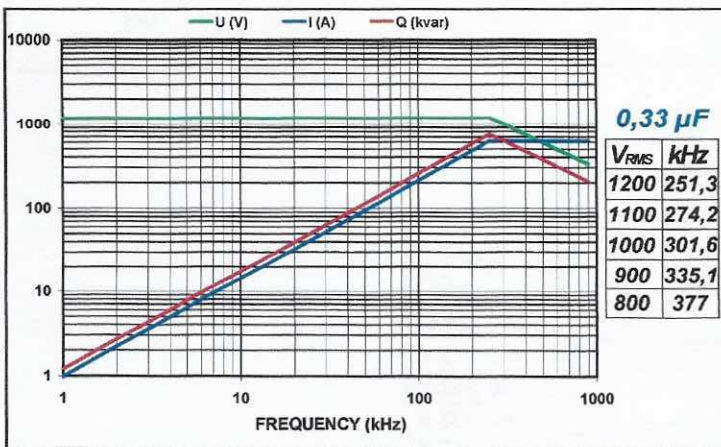
SERIE HFAL – AZ – CC  
 SERIE HFAL – AZ – CD  
 SERIE HFCU – AZ – CC  
 SERIE HFCU – AZ – CD

VALORI CAPACITIVI DIVERSI SU RICHIESTA  
 DIFFERENT CAPACITANCE VALUES ON REQUEST



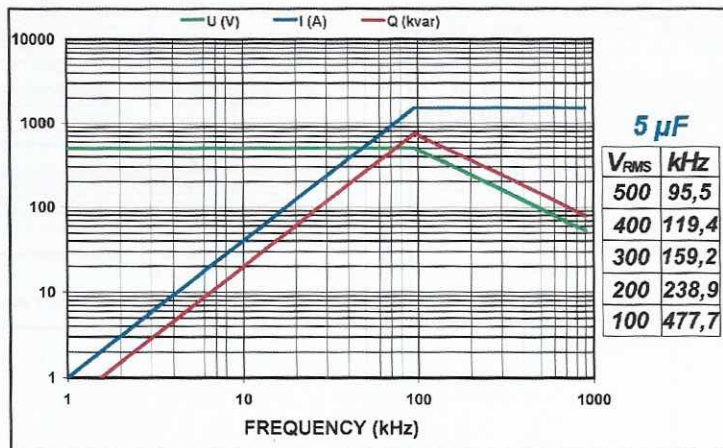
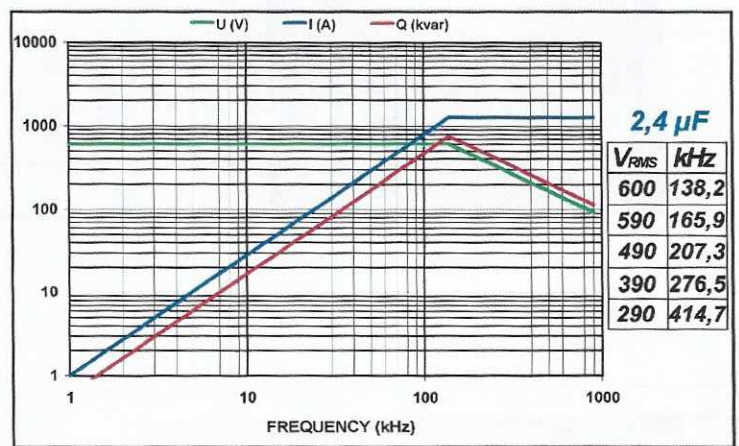
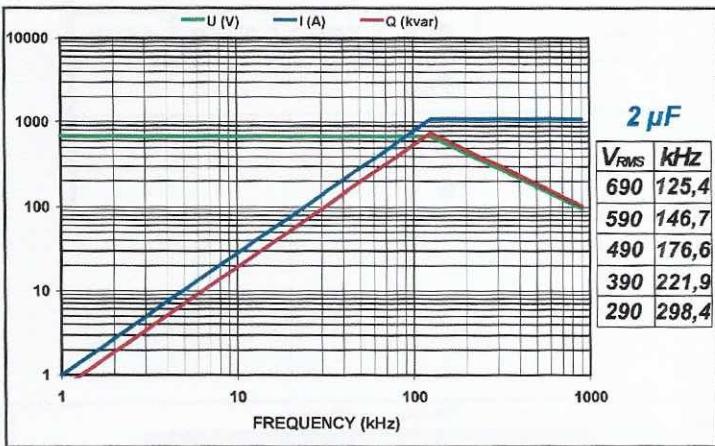
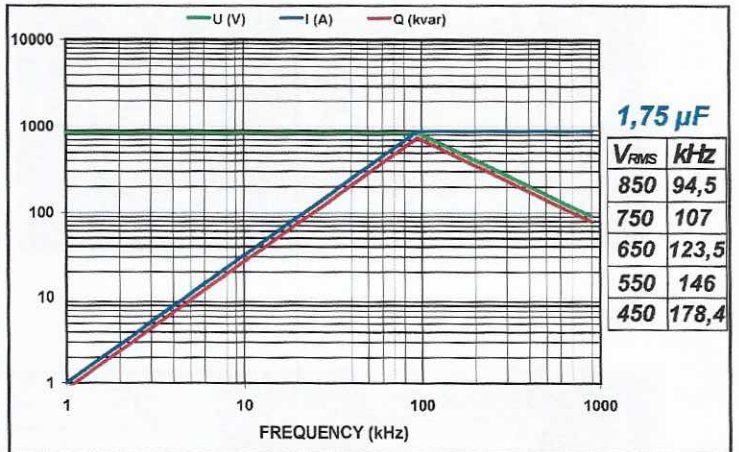
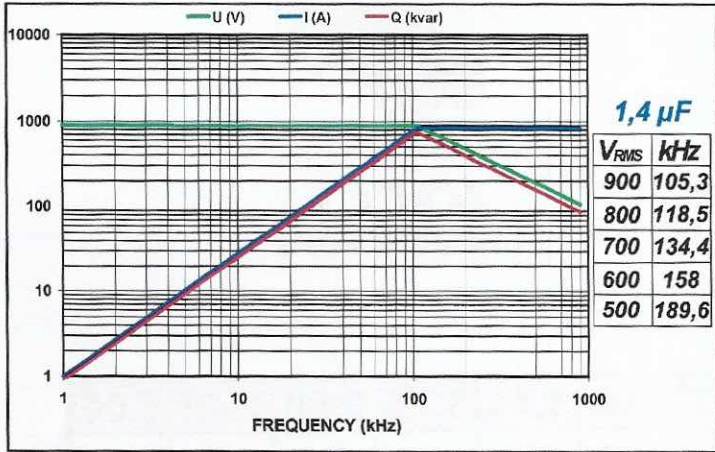
**Ø 80 x h 71,5**

<b>µF</b>	<b>0,33</b>	<b>1,00</b>	<b>1,40</b>	<b>1,75</b>	<b>2,00</b>	<b>2,40</b>	<b>5,00</b>
<b>V</b>	1200	1100	900	850	690	600	500
<b>kHz</b>	297,9	98,3	70,2	106,6	125,4	138,2	95,5
<b>A</b>	556			938	1087	1250	1500
<b>kvar</b>	750						
<b>nH (L<sub>stray</sub>)</b>	≤ 5						
<b>Kg</b>	≈ 1						





**CONDENSATORI PER FORNI A INDUZIONE**  
**INDUCTION HEATING CAPACITORS**  
**CAPACITORS IN TOUCH WITH YOUR NEEDS**






**CONDENSATORI PER FORNI A INDUZIONE**  
**INDUCTION HEATING CAPACITORS**  
**CAPACITORS IN TOUCH WITH YOUR NEEDS**

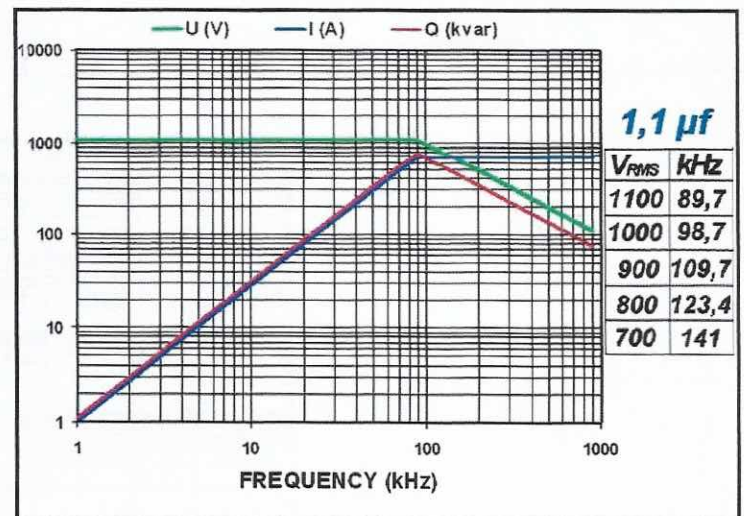
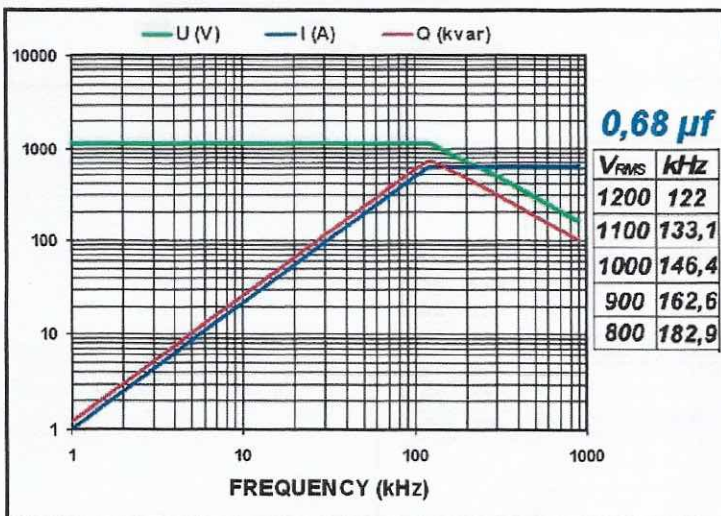


SERIE HFAL – AZ – CC  
 SERIE HFAL – AZ – CD  
 SERIE HFCU – AZ – CC  
 SERIE HFCU – AZ – CD

VALORI CAPACITIVI DIVERSI SU RICHIESTA  
 DIFFERENT CAPACITANCE VALUES ON REQUEST

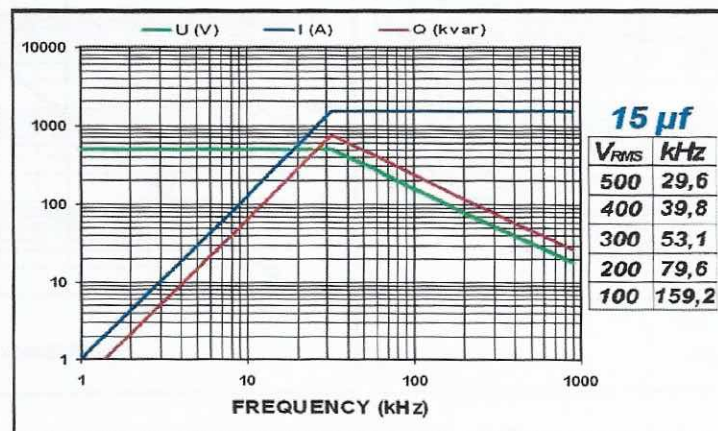
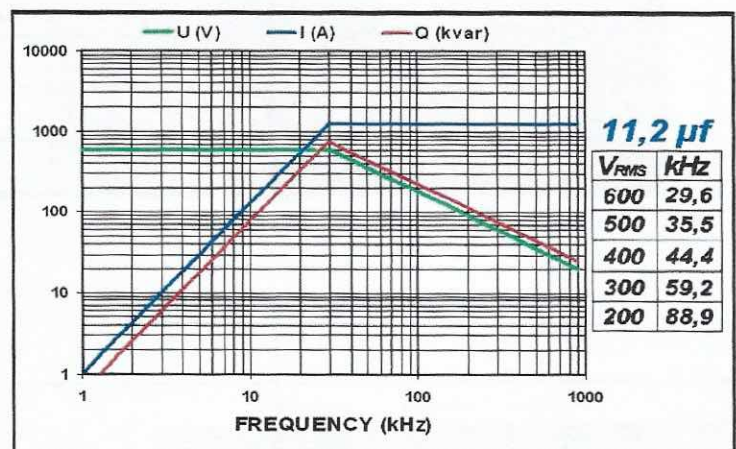
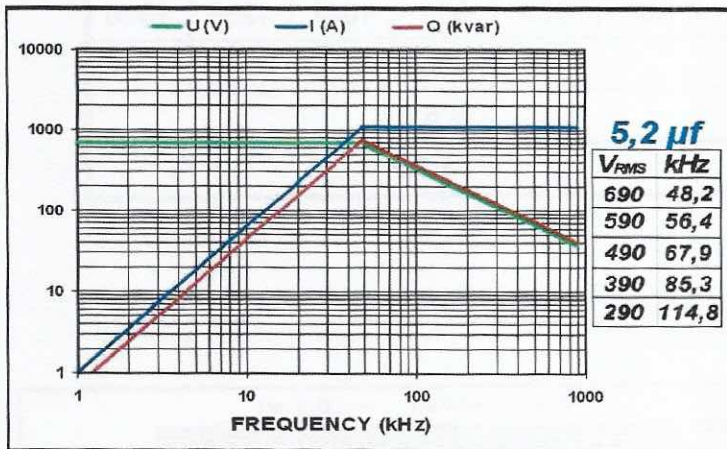
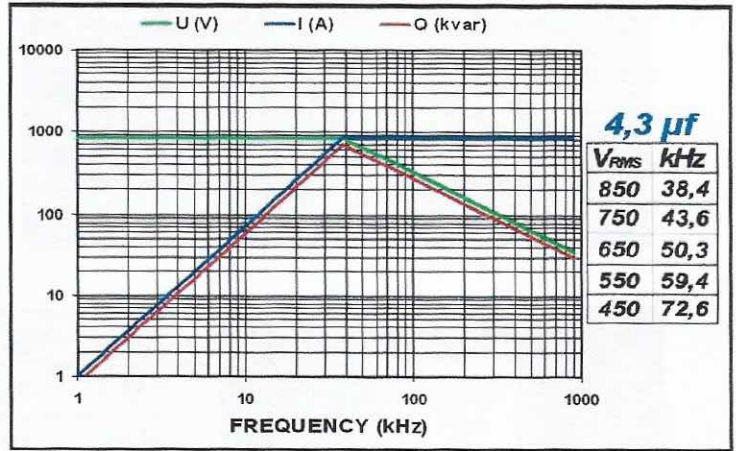
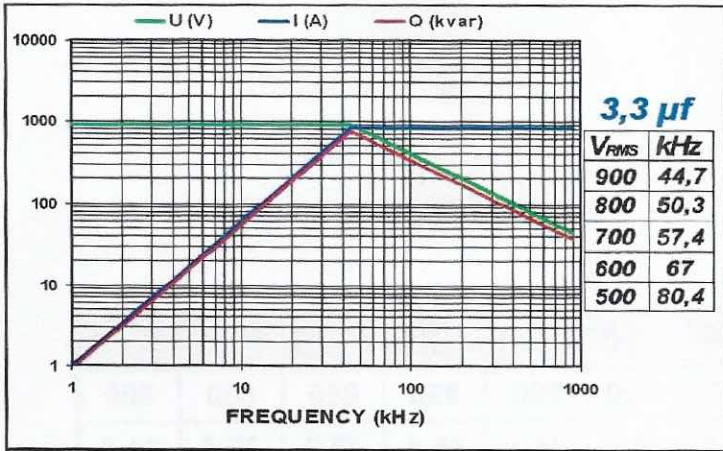


 <b>Ø 100 x h 71,5</b>	<b>µF</b>	<b>0,68</b>	<b>1,10</b>	<b>3,30</b>	<b>4,30</b>	<b>5,20</b>	<b>11,2</b>	<b>15,0</b>
	<b>V</b>	<b>1200</b>	<b>1100</b>	<b>900</b>	<b>850</b>	<b>690</b>	<b>600</b>	<b>500</b>
	<b>kHz</b>	<b>122,0</b>	<b>89,7</b>	<b>44,7</b>	<b>38,4</b>	<b>48,2</b>	<b>29,6</b>	<b>31,8</b>
	<b>A</b>	<b>625</b>	<b>682</b>	<b>833</b>	<b>882</b>	<b>1087</b>	<b>1250</b>	<b>1500</b>
	<b>kvar</b>	<b>750</b>						
	<b>nH (L<sub>stray</sub>)</b>	<b>≤ 5</b>						
	<b>Kg</b>	<b>≈ 1,70</b>						





**CONDENSATORI PER FORNI A INDUZIONE**  
**INDUCTION HEATING CAPACITORS**  
**CAPACITORS IN TOUCH WITH YOUR NEEDS**





**CONDENSATORI PER FORNI A INDUZIONE**  
**INDUCTION HEATING CAPACITORS**  
**CAPACITORS IN TOUCH WITH YOUR NEEDS**



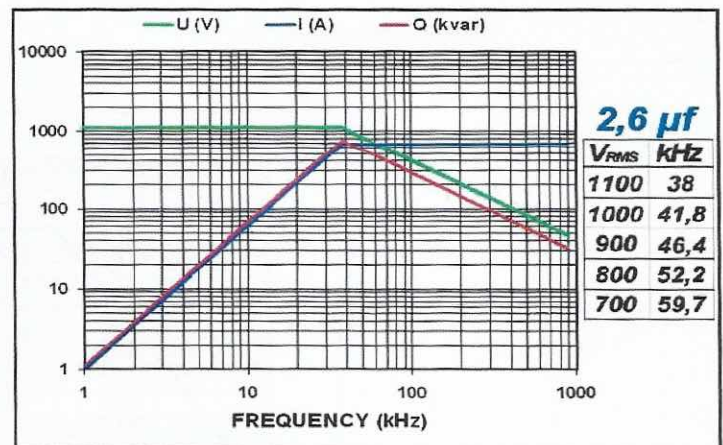
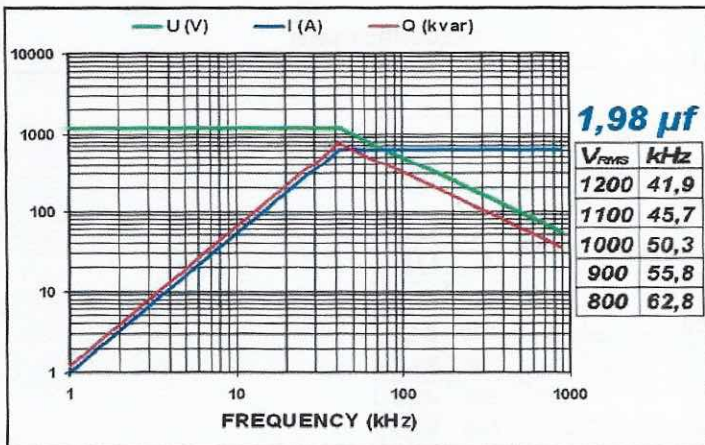
SERIE HFAL – AZ – CC  
 SERIE HFAL – AZ – CD  
 SERIE HFCU – AZ – CC  
 SERIE HFCU – AZ – CD

VALORI CAPACITIVI DIVERSI SU RICHIESTA  
 DIFFERENT CAPACITANCE VALUES ON REQUEST



**Ø 125 x h 71,5**

$\mu\text{F}$	1,98	2,60	4,80	10,0	11,0	15,0	24,0
V	1200	1100	900	850	690	600	500
kHz	41,9	38,0	30,7	16,5	22,8	22,1	19,9
A	625	682	833	882	1087	1250	1500
kvar	750						
nH ( $L_{\text{stray}}$ )	$\leq 5$						
Kg	$\approx$						

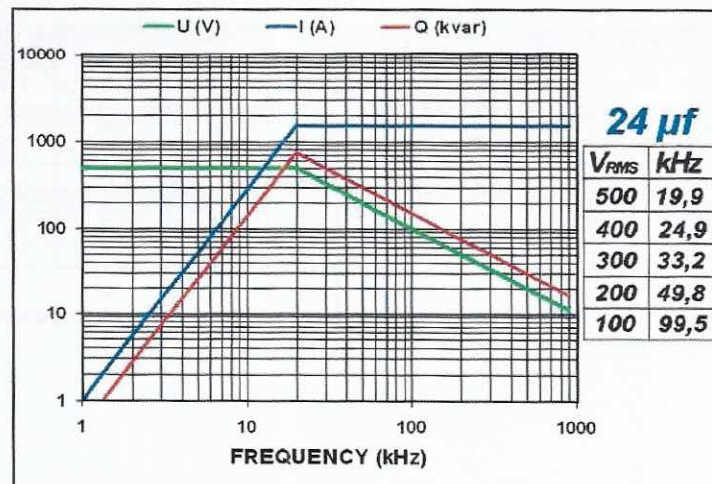
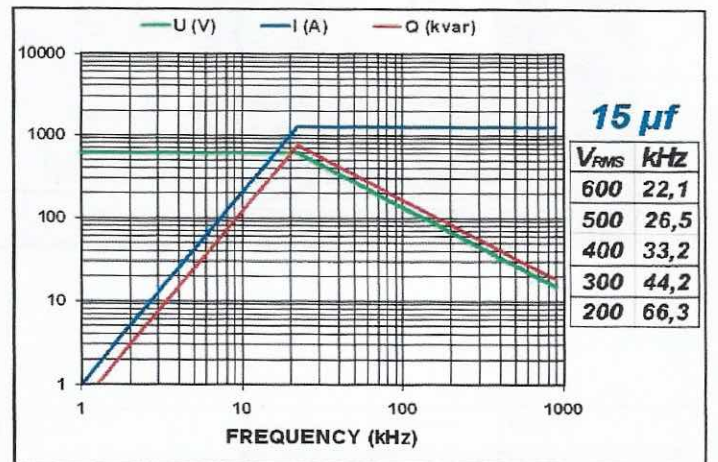
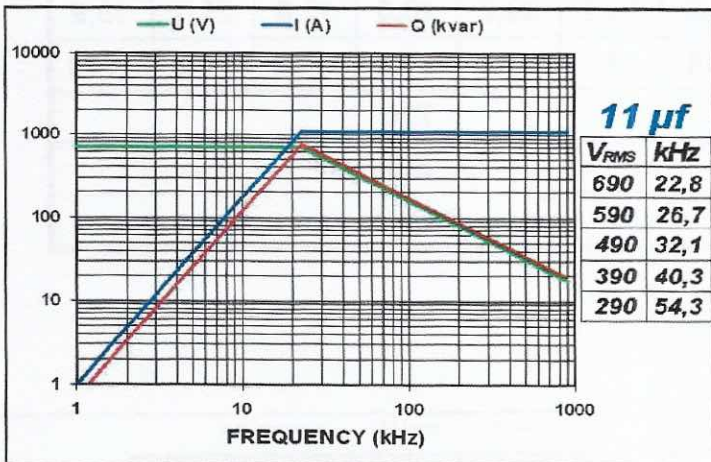
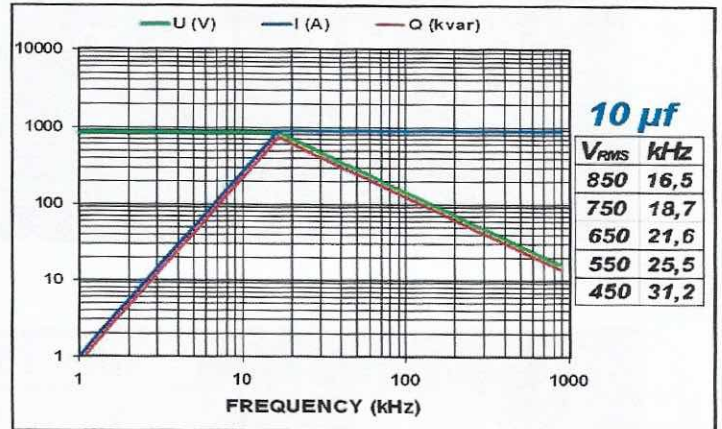
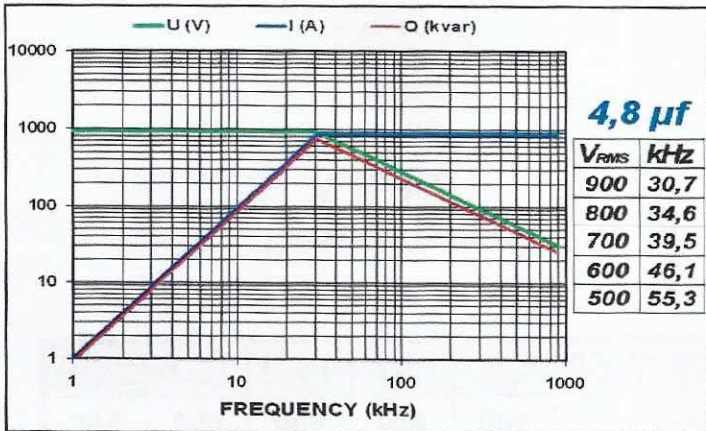




# CONDENSATORI PER FORNI A INDUZIONE

## INDUCTION HEATING CAPACITORS

### CAPACITORS IN TOUCH WITH YOUR NEEDS





**CONDENSATORI PER FORNI A INDUZIONE**  
**INDUCTION HEATING CAPACITORS**  
**CAPACITORS IN TOUCH WITH YOUR NEEDS**



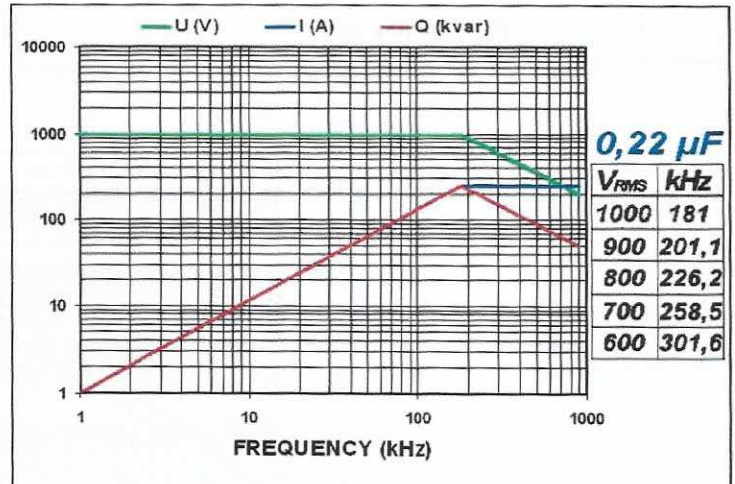
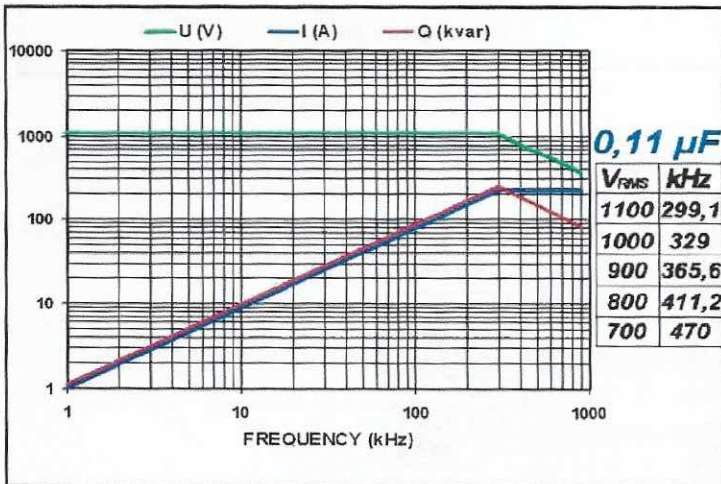
**SERIE HFCU – AA – CC**

VALORI CAPACITIVI DIVERSI SU RICHIESTA  
 DIFFERENT CAPACITANCE VALUES ON REQUEST



**Ø 50 x h 51,5**

<b>µF</b>	<b>0,11</b>	<b>0,22</b>	<b>0,33</b>	<b>0,47</b>	<b>0,68</b>	<b>2,25</b>	<b>3,00</b>
<b>V</b>	<b>1100</b>	<b>1000</b>	<b>900</b>	<b>850</b>	<b>690</b>	<b>500</b>	<b>450</b>
<b>kHz</b>	<b>299,1</b>	<b>180,9</b>	<b>148,9</b>	<b>117,2</b>	<b>123,0</b>	<b>70,8</b>	<b>65,5</b>
<b>A</b>	<b>227</b>	<b>250</b>	<b>278</b>	<b>294</b>	<b>362</b>	<b>500</b>	<b>556</b>
<b>kvar</b>	<b>250</b>						
<b>nH (L<sub>stray</sub>)</b>	<b>≤ 5</b>						
<b>Kg</b>	<b>≈ 0,85</b>						

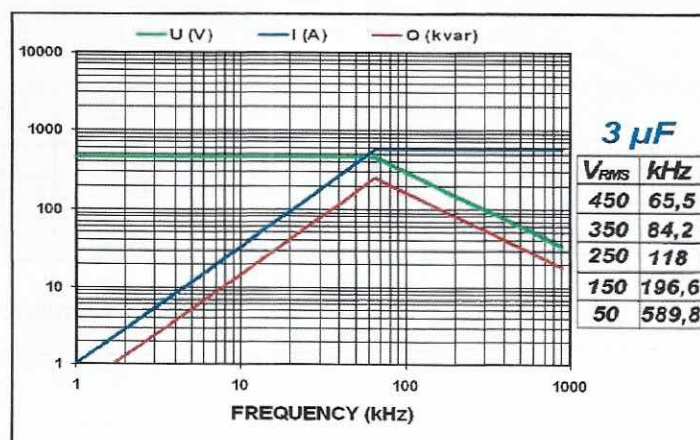
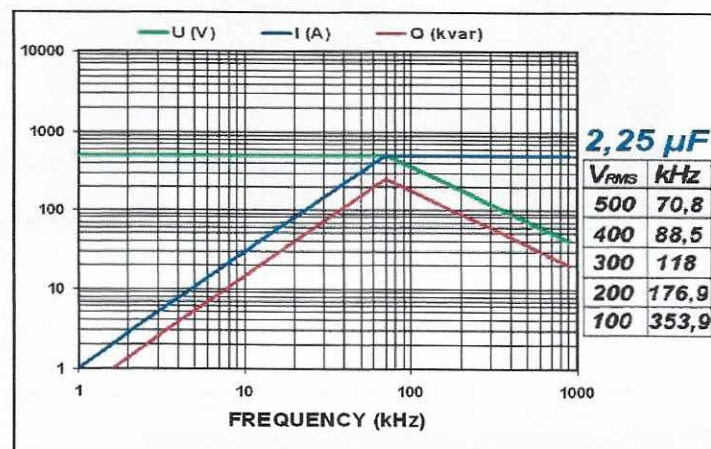
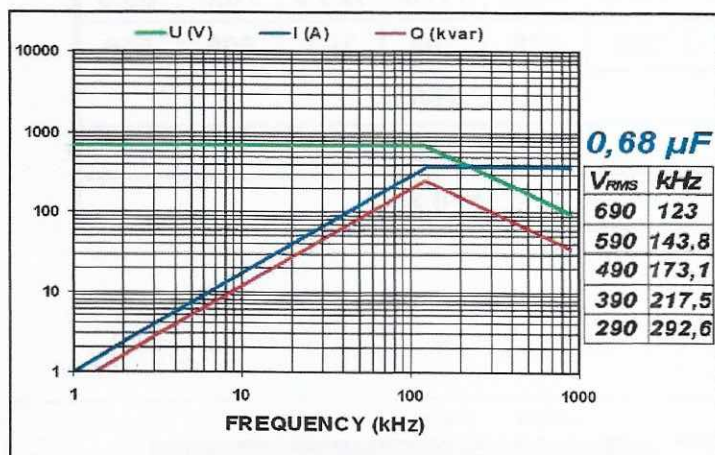
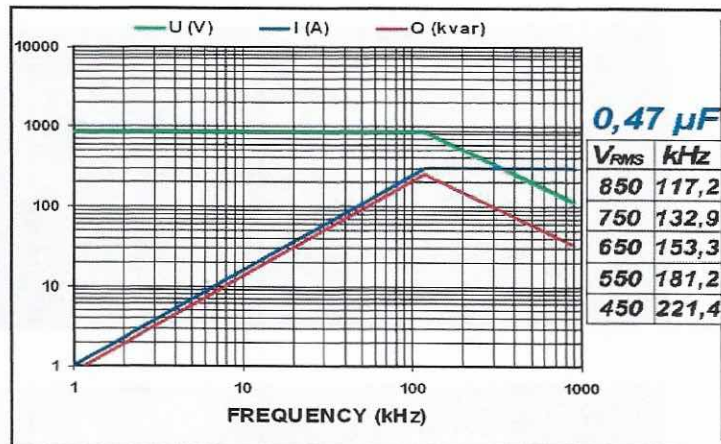
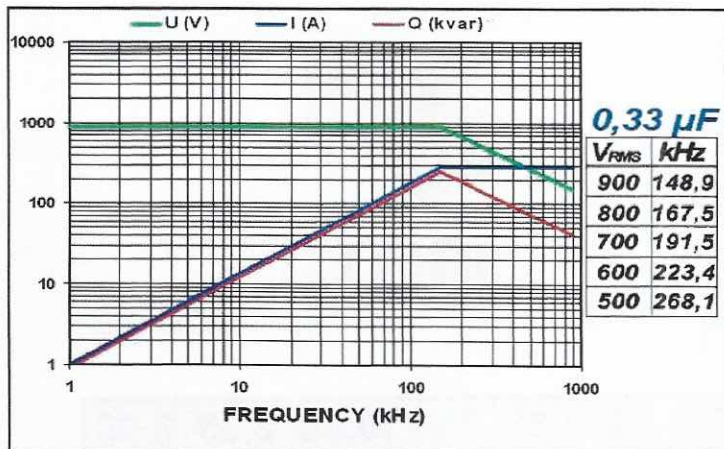




# CONDENSATORI PER FORNI A INDUZIONE

## INDUCTION HEATING CAPACITORS

### CAPACITORS IN TOUCH WITH YOUR NEEDS





**CONDENSATORI PER FORNI A INDUZIONE**  
**INDUCTION HEATING CAPACITORS**  
**CAPACITORS IN TOUCH WITH YOUR NEEDS**



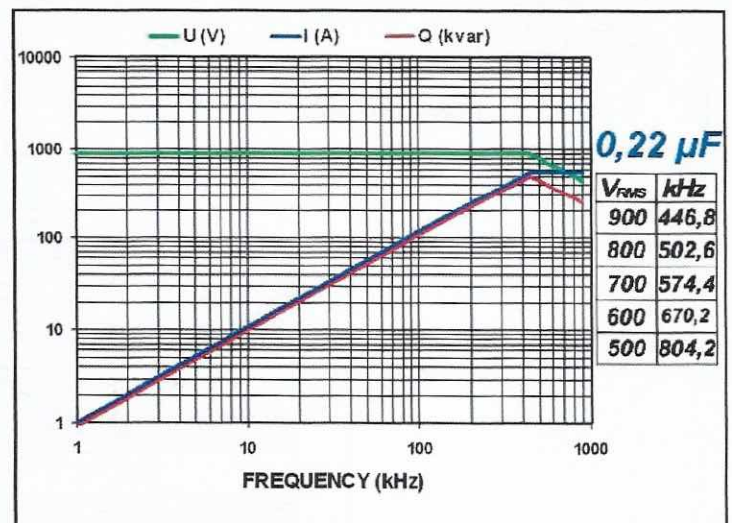
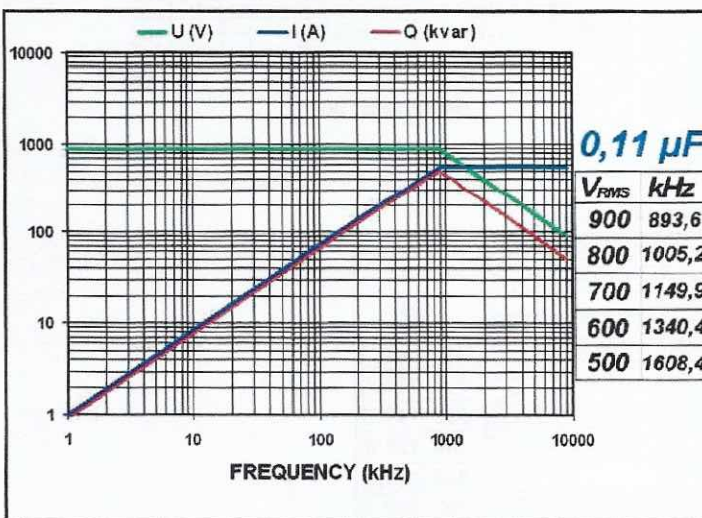
**SERE HFCU – AA – CD**

VALORI CAPACITIVI DIVERSI SU RICHIESTA  
 DIFFERENT CAPACITANCE VALUES ON REQUEST



**Ø 80 x h 71,5**

<b>µF</b>	<b>0,11</b>	<b>0,22</b>	<b>0,33</b>	<b>1,00</b>	<b>1,40</b>	<b>1,75</b>	<b>2,00</b>
<b>V</b>	<b>900</b>					<b>850</b>	<b>690</b>
<b>kHz</b>	<b>893,6</b>	<b>446,8</b>	<b>297,9</b>	<b>98,3</b>	<b>70,2</b>	<b>94,5</b>	<b>125,4</b>
<b>A</b>	<b>556</b>					<b>882</b>	<b>1087</b>
<b>kvar</b>	<b>500</b>					<b>750</b>	
<b>nH (L<sub>stray</sub>)</b>	<b>≤ 5</b>						
<b>Kg</b>	<b>≈ 1</b>						

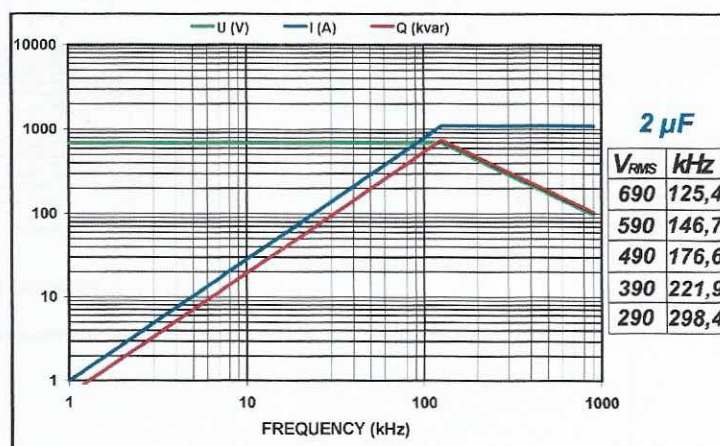
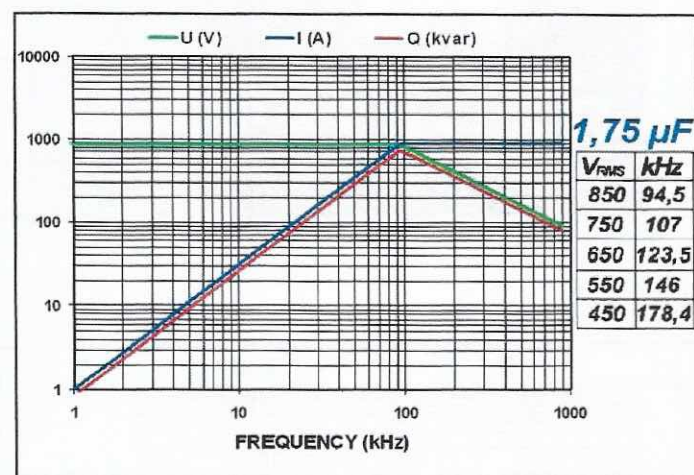
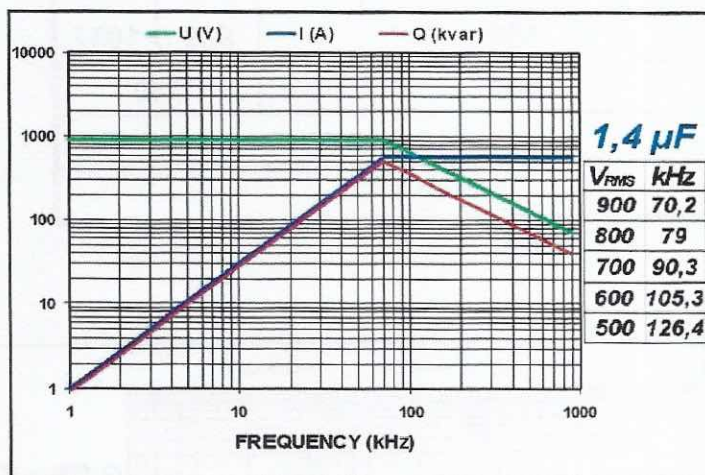
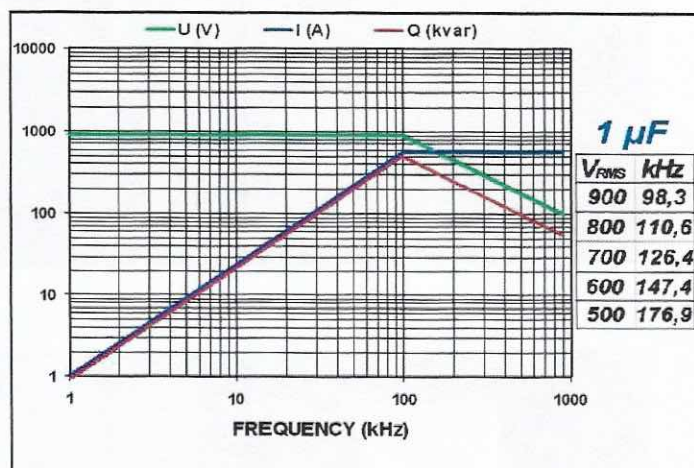
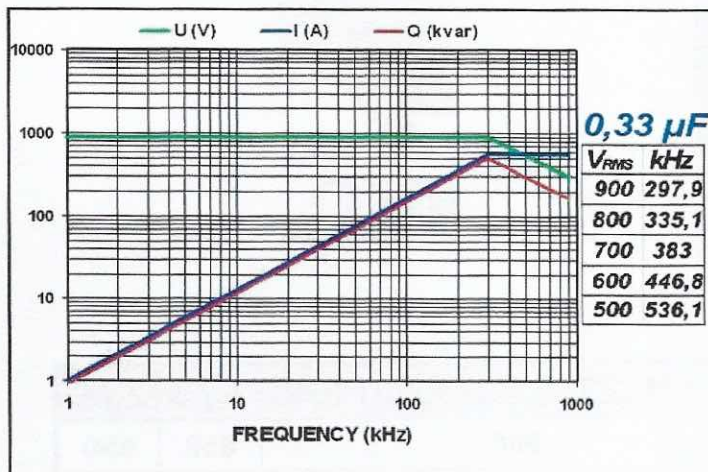




# CONDENSATORI PER FORNI A INDUZIONE

## INDUCTION HEATING CAPACITORS

### CAPACITORS IN TOUCH WITH YOUR NEEDS





**CONDENSATORI PER FORNI A INDUZIONE**  
**INDUCTION HEATING CAPACITORS**  
**CAPACITORS IN TOUCH WITH YOUR NEEDS**



SERIE HFAL – AZ – QD  
 SERIE HFCU – AZ – QD  
 SERIE HFAL – AA – QD  
 SERIE HFCU – AA – QD

VALORI CAPACITIVI DIVERSI SU RICHIESTA  
 DIFFERENT CAPACITANCE VALUES ON REQUEST



BASE (mm) : **150 x 150**  
 HEIGHT (mm): **78,5**

$\mu\text{F}$	2,30	2,80	3,70	13,0	19,0	48,0	80,0
$V_{AC}$	1200	1100	1000	900	850	600	500
kHz	36,0	35,2	32,3	11,4	11,6	9,5	8,0
A	625	682	750	833	1176	1667	2000
kvar	750				1000		
nH ( $L_{\text{stray}}$ )	< 5						
Kg	$\leq 1,75$						





**CONDENSATORI PER FORNI A INDUZIONE**  
**INDUCTION HEATING CAPACITORS**  
**CAPACITORS IN TOUCH WITH YOUR NEED**

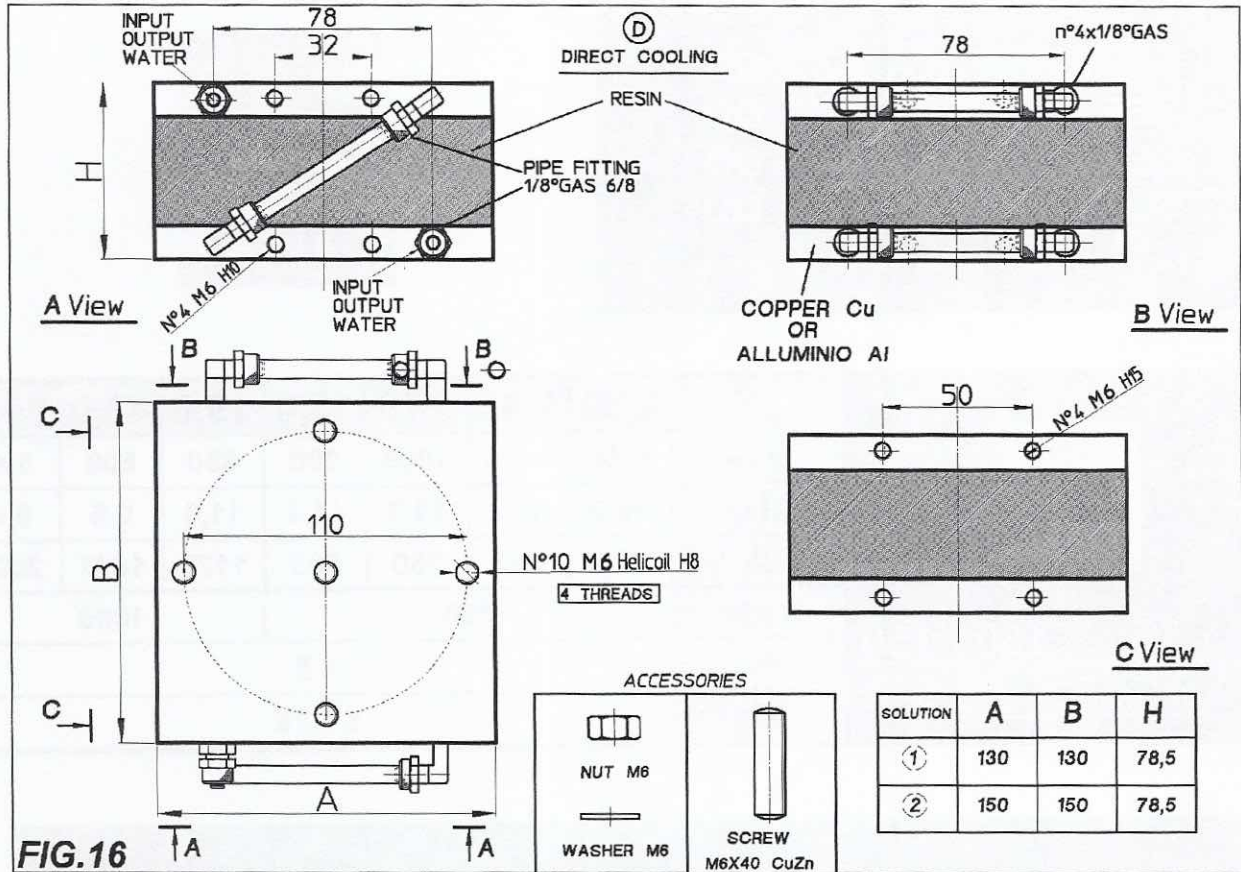
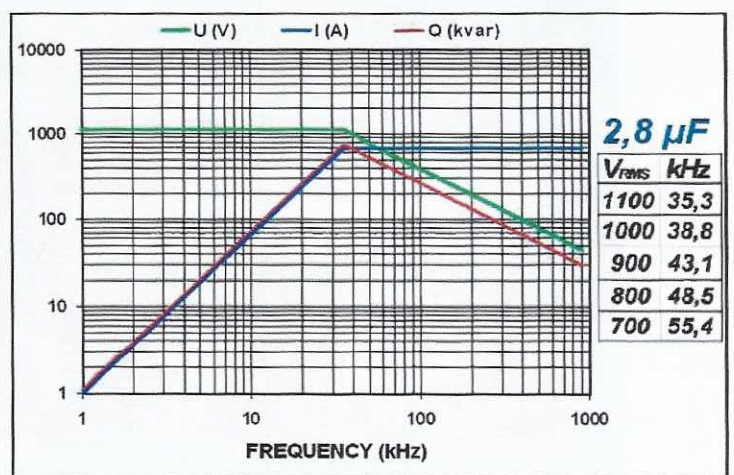
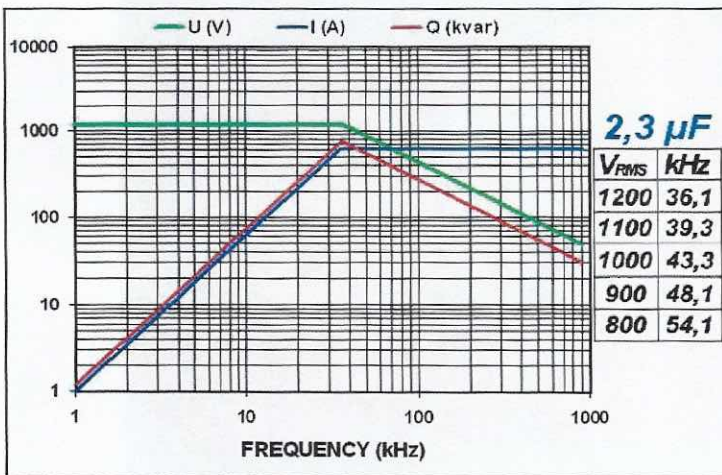
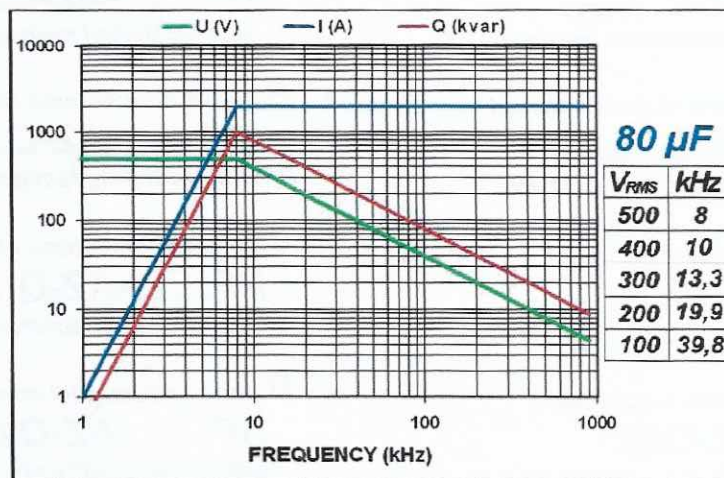
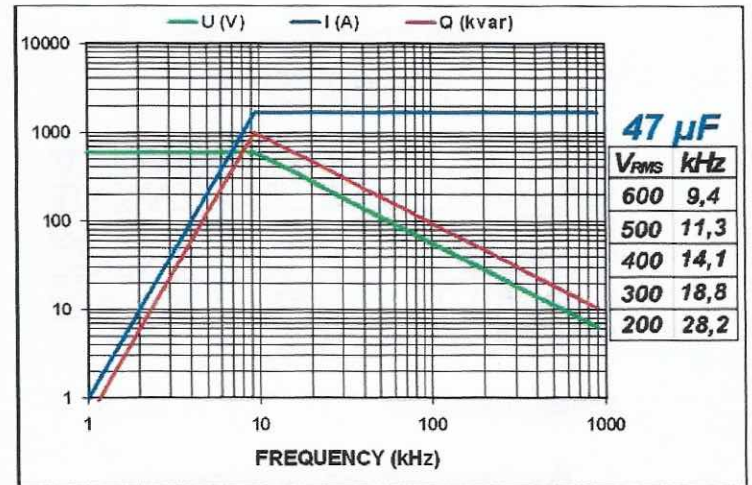
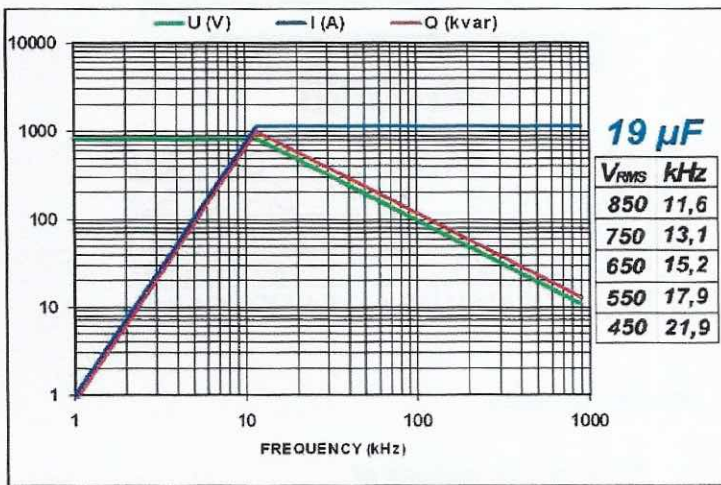
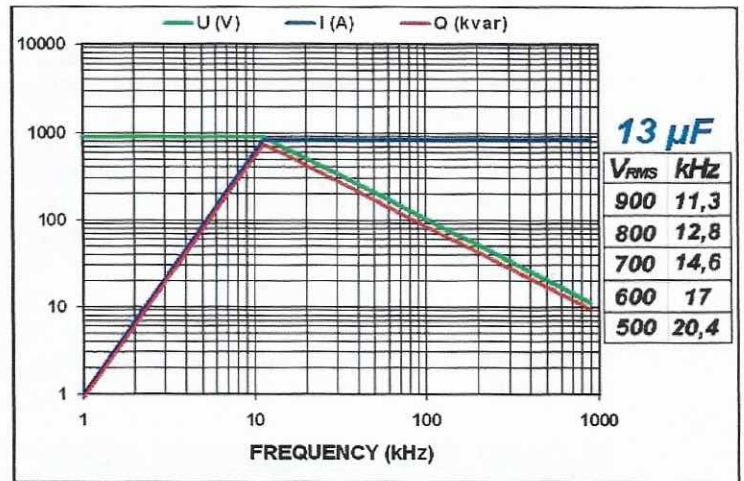
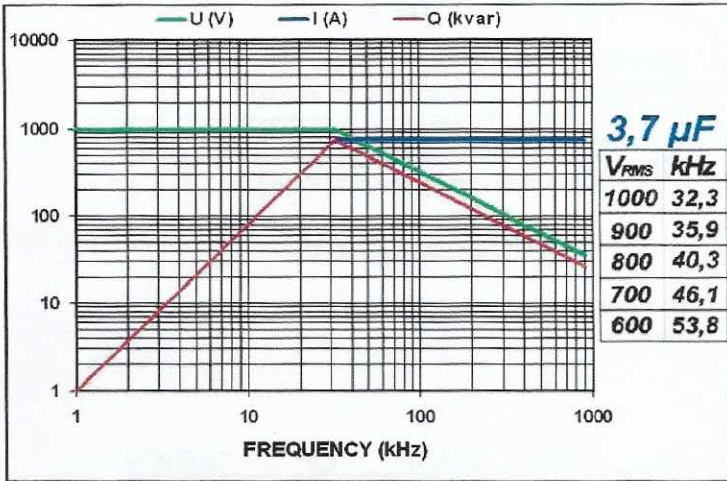


FIG.16





**CONDENSATORI PER FORNI A INDUZIONE**  
**INDUCTION HEATING CAPACITORS**  
**CAPACITORS IN TOUCH WITH YOUR NEED**





**CONDENSATORI PER FORNI A INDUZIONE**  
**INDUCTION HEATING CAPACITORS**  
**CAPACITORS IN TOUCH WITH YOUR NEEDS**



**METODI DI MONTAGGIO**

L'utilizzo dei condensatori oltre che dalla frequenza è strettamente condizionato dalla tensione di servizio.

e  $U_{AC} \leq 1200 \text{ V}$  , il collegamento è diretto, se  $U_{AC} > 1200 \text{ V}$  sono attuabili COLLEGAMENTI SERIE DIRETTI che permettono l'utilizzo dei condensatori fino a valori di tensione pari a

$$U_{AC} \leq 2500 \text{ V}$$

Le combinazioni possono essere eseguite in vari modi:

**IN CASO DI COLLEGAMENTO SERIE DIRETTO DI DUE UNITÀ'**

**E' NECESSARIO E IMPORTANTE**

**CHE LE TESTATE CENTRALI DI CONTATTO SIANO DIRETTAMENTE RAFFREDDATE IN QUANTO IL SOLO TRASFERIMENTO DI CALORE VERSO I CONTATTI ESTERNI PUÒ' NON ESSERE SUFFICIENTE.**

Soluzioni possibili:

- **A** collegamento serie di condensatori **HF.....-AZ-C..** senza possibilità di sostituzione parziale.
- **B** collegamento serie di condensatori **HF.....-AZ-C..** con possibilità di sostituzione parziale.
- **C** collegamento serie. **HF.....-AZ-Q..** con possibilità di sostituzione parziale.
- **D** collegamento serie o parallelo **HF.....-AZ-Q2D** senza possibilità di sostituzione parziale.

**ASSEMBLY METHODS**

Capacitors use is not only conditioned by the frequency but tightly by service voltage.

If  $U_{AC} \leq 1200 \text{ V}$ , the connection is direct, if  $U_{AC} > 1200 \text{ V}$  series/parallel connections can be used to allow the use of capacitors till

$$U_{AC} \leq 2500 \text{ V}$$

The combinations may be executed in different ways;

**IN THE CASE OF SERIES CONNECTION BETWEEN TWO UNITS**

**IT IS NECESSARY AND IMPORTANT**

**THAT CONTACT CENTRAL CONNECTIONS ARE DIRECTELY WATER COOLED BECAUSE THE ONLY HOT-SWAPPING TO EXTERNAL CONTACTS MAY BE NOT SUFFICIENT.**

Possible solutions:

- **A** series connections of **HF.....-AZ-C...** with no partial replacement
- **B** series connections of **HF.....-AZ-C...** with partial replacement
- **C** series connections of **HF.....-AZ-Q...** with partial replacement
- **D** serie and parallel connection of **HF.....-AZ-Q2D** with no possibility of partial replacement





# CONDENSATORI PER FORNI A INDUZIONE INDUCTION HEATING CAPACITORS CAPACITORS IN TOUCH WITH YOUR NEEDS



## SOLUZIONE A-B – A-B SOLUTION







# CONDENSATORI PER FORNI A INDUZIONE

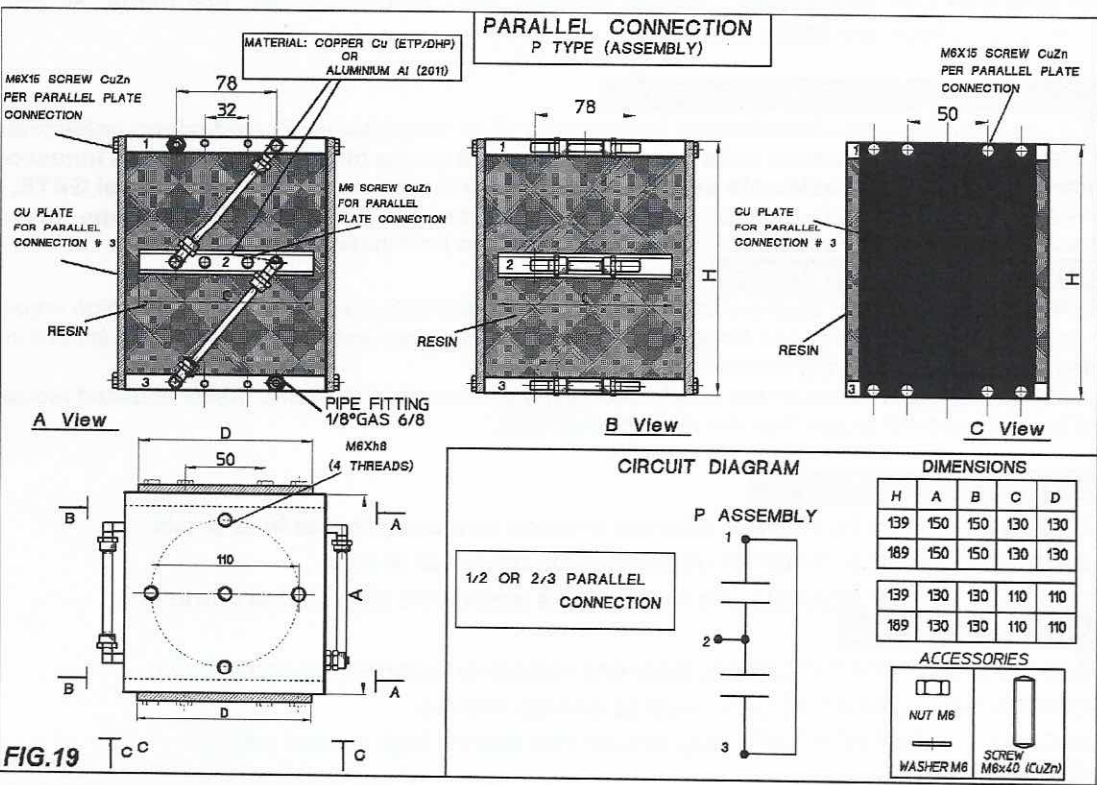
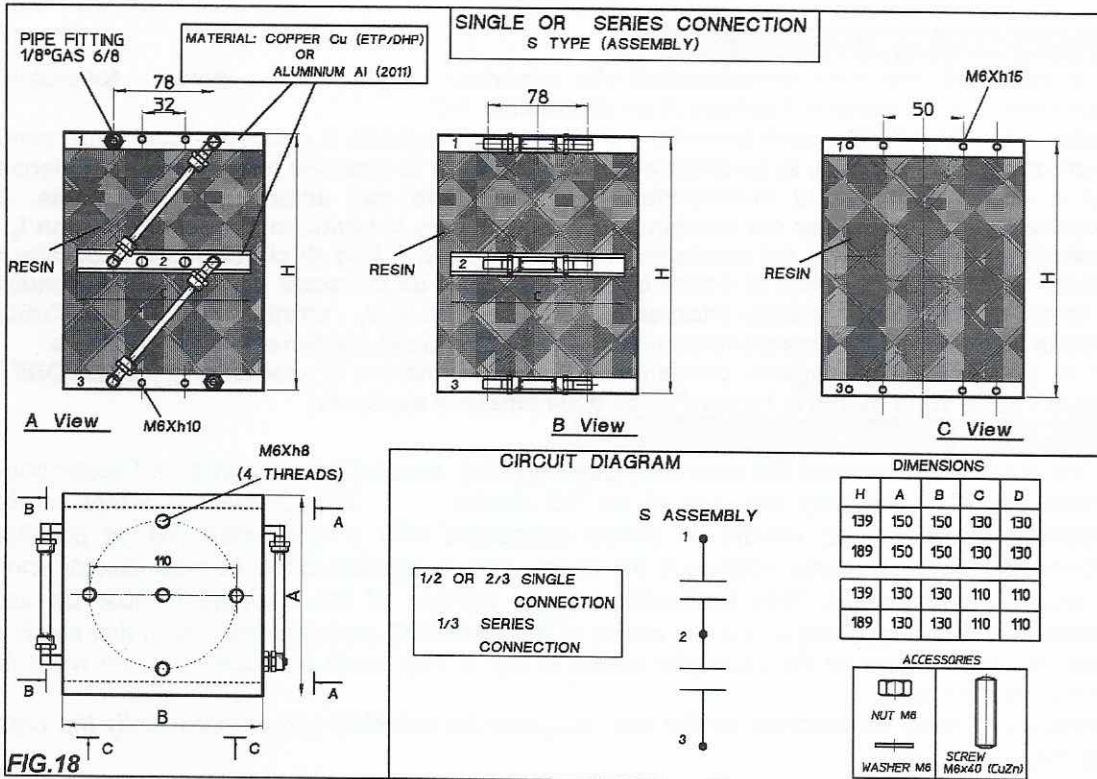
## INDUCTION HEATING CAPACITORS

### CAPACITORS IN TOUCH WITH YOUR NEEDS



# D

## SOLUZIONE D - D SOLUTION





## CONDENSATORI PER FORNI A INDUZIONE INDUCTION HEATING CAPACITORS CAPACITORS IN TOUCH WITH YOUR NEEDS



### COMPLETAMENTO DI SISTEMA SYSTEM FINISHING

#### **CONDENSATORI DI PROTEZIONE**

Con lo scopo di prevenire sovratensioni che superano valori di picco tollerabili dai semiconduttori è necessario l'utilizzo di un dispositivo RC.

L'effetto di DAMPING ( smorzamento ) è ottenuto collegando il condensatore, generalmente in serie ad una resistenza ( R ), in parallelo al semiconduttore: la tensione operativa sul condensatore è simile a quella applicata al semiconduttore e raramente con andamento sinusoidale. Questa particolare tensione di carico del condensatore deve essere valutata, in concomitanza con  $I_p$ , nella progettazione e nella scelta dei condensatori di DAMPING: il tipo di circuito che necessita di tale "servizio" è molto vario perciò la scelta del condensatore da utilizzare è strettamente condizionata dalla forma d'onda su cui occorre intervenire. Noto il valore di  $U_p$ , strettamente legato all'utilizzo, si determina  $U_{rms}$  che è il riferimento fondamentale nella scelta del condensatore da utilizzare.

I tipi di circuiti che impiegano condensatori, la cui funzione è quella di PROTEZIONE, sono molteplici, varie sono quindi le forme d'onda della tensione applicate.

#### **DAMPING OR SNUBBER CAPACITORS**

*With the purpose to prevent the over-voltages that may exceed peak values that semiconductors can tolerate, it's necessary the use of an RC device. The DAMPING effect is obtained connecting the capacitor, usually in series connected with a resistance (R), in parallel to a semiconductor: the capacitor voltage is the same voltage applied to the semiconductor and rarely with sinusoidal movement. This particular charge voltage of the capacitor must be valued considering  $I_p$  in the designing and in the choice of the DAMPING capacitor: the circuit that needs such a "service" is very complex so the capacitor choice to use is very much conditioned by the wave form on which it's forced to work.*

*Knowing  $U_p$ , closely conditioned by the use,  $U_{rms}$  may be valued and consequently the capacitor to use may be chosen.*

*The circuits that use capacitors, whose function is of PROTECTION, are many, so the wave forms of used voltage are many too.*

#### **CONDENSATORI DI COMMUTAZIONE**

L'SCR è un dispositivo semiconduttore in possesso di caratteristiche di conduzione unidirezionale, che presenta un'alta impedenza nella direzione opposta a quella diretta per cui è stato innescata la conduzione. L' SCR è normalmente attivato applicando una piccola entità di corrente al GATE. Una volta attivato l'SCR continua a condurre fino alla commutazione (turn-off) che si ottiene riducendo la corrente per un periodo di tempo più elevato del tempo nominale di turn-off.

#### **COMMUTATION CAPACITORS**

*The SCR is a semiconductor device with conduction unidirectional features, that has a very high impedance in the opposite direction to that one for which the conduction has been switched on. The SCR is normally activated applying a small entity current to the GATE.*

*Once activated the SCR keeps on the conduction till the commutation (turn-off), that is obtained reducing the current for a time period longer than the rated turn-off time.*

#### **CONDENSATORI DI FILTRO**

- CONDENSATORI DI FILTRO per tollerare e ridurre una componente in alternata.
- CONDENSATORI DI SUPPORTO utilizzati come riserva di energia.
- CONDENSATORI DI SCARICA che forniscono e assorbono alti valori di corrente.

#### **FILTER CAPACITORS**

- SMOOTHING CAPACITORS to bear and reduce an alternating component.
- SUPPORTING CAPACITORS used as energy reserve.
- DISCHARGE CAPACITORS they supply and absorb high current values.





**CONDENSATORI PER FORNI A INDUZIONE**  
**INDUCTION HEATING CAPACITORS**  
**CAPACITORS IN TOUCH WITH YOUR NEEDS**



**CONDENSATORI DI PROTEZIONE**

Questo prodotto, la cui tipologia di avvolgimento è finalizzata a valori di induttanza (L) molto bassi, offre ottime prestazioni anche ad alte frequenza (f) abbinate a valori di resistenza (R) serie ridottissimi così da attenuare enormemente le dissipazioni. Con queste caratteristiche di prodotto la serie (SM) può tollerare alte correnti di picco ( $I_p$ ) ed efficaci ( $I_{RMS}$ ) offrendo perdite bassissime ed alta stabilità capacitiva associate a un numero elevatissimo di ore di vita al variare della temperatura ambiente.

I condensatore della serie SM sono normalmente utilizzati per la **COMMUTAZIONE** forzata dei **THYRISTOR (SCR)**, la **PROTEZIONE (SNUBBER)** e **FILTRAGGIO**.

**DAMPING OR SNUBBER CAPACITORS**

*This item, whose winding typology is finalized to very low inductance (L) values, offers excellent results also at high frequency (f) linked to values of series resistance (R) very low to attenuate enormously losses. With these features SM series products may tolerate high peak currents ( $I_p$ ) and high  $I_{RMS}$  offering very low losses and high stability of capacitor also after many hours of life in an ambient with variable temperature. SM series capacitors are normally used for forced **COMMUTATION** of **THYRISTOR (SCR)**, for the **PROTECTION (SNUBBER)** and **FILTERING**.*

<b>I-SMR-C</b>	<b>SOLUZIONE CON INTERRUZIONE PER SOVRAPRESSIONE (S2)</b> <i>SOLUTION WITH OVERPRESSURE DISCONNECTOR (S2)</i>			
<b>CAPACITA'</b> <b>CAPACITANCE</b>	<b>V<sub>RMS</sub></b>	<b>V<sub>P</sub></b>	<b>V<sub>PP</sub></b>	<b>V<sub>DC</sub></b>
<b>0,1 ≤ μF ≤ 3,30</b>	<b>500</b>	<b>700</b>	<b>1000</b>	<b>1500</b>
<b>0,01 ≤ μF ≤ 2,20</b>	<b>750</b>	<b>1050</b>	<b>1500</b>	<b>2250</b>

<b>I-SMH-C</b>	<b>SOLUZIONE CON ARMATURA PESANTE (S0)</b> <i>HEAVY FOIL SOLUTION (S0)</i>			
<b>CAPACITA'</b> <b>CAPACITANCE</b>	<b>V<sub>RMS</sub></b>	<b>V<sub>P</sub></b>	<b>V<sub>PP</sub></b>	<b>V<sub>DC</sub></b>
<b>0,01 ≤ μF ≤ 2,50</b>	<b>1000</b>	<b>1410</b>	<b>2000</b>	<b>3000</b>
<b>0,01 ≤ μF ≤ 2,00</b>	<b>1500</b>	<b>2115</b>	<b>3000</b>	<b>4500</b>





**CONDENSATORI PER FORNI A INDUZIONE**  
**INDUCTION HEATING CAPACITORS**  
**CAPACITORS IN TOUCH WITH YOUR NEEDS**



**CONDENSATORI DI COMMUTAZIONE**

Per definire il valore capacitivo del condensatore finalizzato alla commutazione di SCR in un determinato circuito, occorre conoscere l'energia di TURN-OFF del semiconduttore in oggetto ed eguagliarla alla relazione tipica dei condensatori, che lega l'energia accumulata durante la carica alla capacità e al voltaggio esistente tra le armature:

- W** energia necessaria per la commutazione
- C** capacità incognita
- U** tensione sul condensatore

COMMUTATION CAPACITORS

To determine the value of the capacitor finalized to SCR commutation in a fixed circuit, it's important to know the energy of TURN-OFF of the considered semiconductor and equalize it to the typical formula that matches the accumulated energy during the charge to the capacitor and to the existing

voltage between foils.

*W* required energy for commutation

*C* capacitance value

*U* capacitor voltage

$$C = \frac{2W}{U^2}$$

I-HCCR...	SOLUZIONE DEAD/LIVE CASE			
	DEAD/LIVE CASE SOLUTION			
CAPACITA' CAPACITANCE	V <sub>RMS</sub>	V <sub>P</sub>	V <sub>PP</sub>	V <sub>DC</sub>
1,0 ≤ μF ≤ 300	250	353	500	750
10 ≤ μF ≤ 200	500	705	1000	1500
2,5 ≤ μF ≤ 100	750	1058	1500	2250
5,0 ≤ μF ≤ 20	1000	1410	2000	3000





## CONDENSATORI PER FORNI A INDUZIONE INDUCTION HEATING CAPACITORS CAPACITORS IN TOUCH WITH YOUR NEEDS



### CONDENSATORI DI FILTRO CON TENSIONI ELEVATE

Questi condensatori sono prodotti con lo scopo di operare da filtri con l'applicazione di tensioni molto elevate e valori di corrente molto limitati. Generalmente vengono utilizzati abbinandoli a triodi ad alta frequenza e potenza limitata.

#### APPLICAZIONI:

- BY-PASS
- ACCOPPIAMENTO
- UTILIZZO COME FILTRO

#### FILTER CAPACITORS WITH HIGH VOLTAGE

*These capacitors are produced with the purpose of operating as FILTERS with very high voltage values and very limited current values. Usually they are used pairing them with air-cooled TRIODES and using high frequency and limited power.*

#### APPLICATIONS:

- BY-PASS.
- COUPLING.
- USED AS A FILTER.





# CONDENSATORI PER FORNI A INDUZIONE INDUCTION HEATING CAPACITORS CAPACITORS IN TOUCH WITH YOUR NEEDS



## CONDENSATORI DI FILTRO

Questa tipologia di condensatore di filtro e' installata su impianti convertitori statici di frequenza ( a valle di un ponte raddrizzatore di tipo trifase interamente controllato con tiristori e a monte di un inverter ) e opera insieme a induttanze di livellamento da filtro DC per la corrente di ripple e contemporaneamente rifasa operando con frequenze fino a 20 kHz.

## SOLUZIONI DI PRODOTTO :

- METALIZED FOIL:
  - 1) AIR COOLED.
  - 2) WATER COOLED.
- HEAVY FOIL "":
  - 1) WATER COOLED.

## FILTER CAPACITORS

*This kind of FILTER capacitors are installed in static frequency CONVERTER plants (down-stream of THREE PHASE RECTIFIER BRIDGE totally controlled with THYRISTOR and up-stream of an INVERTER) and it works together with clamping inductances as DC filter for ripple currents and as power factor correction capacitor for frequency up to 20 kHz.*

## PRODUCT TYPES:

- METALIZED FOIL:
  - 1) AIR COOLED.
  - 2) WATER COOLED.
- HEAVY FOIL "":
  - 1) WATER COOLED.





**CONDENSATORI PER FORNI A INDUZIONE**

**INDUCTION HEATING CAPACITORS**

**CAPACITORS IN TOUCH WITH YOUR NEEDS**



## I-FCR-HFR-2W

**SOLUZIONE "DEAD CASE" - FILM METALLIZZATO -  
DOPPIO RAFFREDDAMENTO CON ACQUA FORZATA**

*"DEAD CASE" SOLUTION - METALIZED FOIL - DOUBLE COOLING SYSTEM WITH FORCED WATER*

<b>CAPACITA' CAPACITANCE</b>	<b>V<sub>RMS</sub></b>	<b>V<sub>DC</sub></b>	<b>V<sub>RIPPLE</sub></b>
<b>500 ≤ μF ≤ 3000</b>	<b>200</b>	<b>400</b>	<b>30</b>
<b>250 ≤ μF ≤ 2000</b>	<b>400</b>	<b>800</b>	<b>40</b>
<b>250 ≤ μF ≤ 500</b>	<b>800</b>	<b>1600</b>	<b>60</b>

## I-FCR-HFR-RE...

**SOLUZIONE "DEAD CASE" - FILM METALLIZZATO -  
DOPPIO RAFFREDDAMENTO DIRETTO CON ACQUA FORZATA**

*"DEAD CASE" SOLUTION - METALIZED FOIL - DOUBLE DIRECT COOLING SYSTEM WITH FORCED WATER*

<b>CAPACITA' CAPACITANCE</b>	<b>V<sub>RMS</sub></b>	<b>V<sub>DC</sub></b>	<b>V<sub>RIPPLE</sub></b>
<b>1000 ≤ μF ≤ 3000</b>	<b>200</b>	<b>400</b>	<b>30</b>
<b>1000 ≤ μF ≤ 2000</b>	<b>400</b>	<b>800</b>	<b>40</b>
<b>250 ≤ μF ≤ 500</b>	<b>800</b>	<b>1600</b>	<b>60</b>

## I-FCH-HFR-2W

**SOLUZIONE "DEAD CASE" - ARMATURA PESANTE -  
DOPPIO RAFFREDDAMENTO CON ACQUA FORZATA**

*"DEAD CASE" SOLUTION - HEAVY FOIL - DOUBLE COOLING SYSTEM WITH FORCED WATER*

<b>CAPACITA' CAPACITANCE</b>	<b>V<sub>RMS</sub></b>	<b>V<sub>DC</sub></b>	<b>V<sub>RIPPLE</sub></b>
<b>500 ≤ μF ≤ 1000</b>	<b>750</b>	<b>1000</b>	<b>40</b>
<b>250 ≤ μF ≤ 750</b>	<b>1250</b>	<b>1700</b>	<b>80</b>
<b>125 ≤ μF ≤ 250</b>	<b>1500</b>	<b>2000</b>	<b>120</b>
<b>200 μF</b>	<b>2000</b>	<b>2500</b>	<b>120</b>





**CONDENSATORI PER FORNI A INDUZIONE**  
**INDUCTION HEATING CAPACITORS**  
**CAPACITORS IN TOUCH WITH YOUR NEEDS**





**CONDENSATORI PER FORNI A INDUZIONE**  
**INDUCTION HEATING CAPACITORS**  
**CAPACITORS IN TOUCH WITH YOUR NEEDS**



Benvenuti alla INCO  
 Welcome to INCO

The map section consists of three parts: a regional map of Northern Italy with INCO marked in Massa Lombarda; a road map showing the location relative to Bologna, Imola, and Ravenna, including the S.S. 16 - Sillero and the A14 Motorway; and a detailed street map of Massa Lombarda with numbered points 1 through 7.

Da / From Bologna	Da / From Ravenna
① Viale della Libertà	⑦ Viale Zeparelli
② Via Imola	⑧ Viale della Resistenza
③ Via Borgo Pescatori	⑨ Via Marchetti
④ Piazza Marmirolo	
⑤ Via Marchetti	



Via Marchetti, 88  
 48024 Massa Lombarda (Ra) - Italia  
 Tel. +39 . 0545 . 81090  
 Fax +39 . 0545 . 81627  
 incosrl@incosrl.com



1900  
1901  
1902

1903  
1904  
1905  
1906  
1907  
1908  
1909  
1910  
1911  
1912  
1913  
1914  
1915  
1916  
1917  
1918  
1919  
1920  
1921  
1922  
1923  
1924  
1925  
1926  
1927  
1928  
1929  
1930  
1931  
1932  
1933  
1934  
1935  
1936  
1937  
1938  
1939  
1940  
1941  
1942  
1943  
1944  
1945  
1946  
1947  
1948  
1949  
1950  
1951  
1952  
1953  
1954  
1955  
1956  
1957  
1958  
1959  
1960  
1961  
1962  
1963  
1964  
1965  
1966  
1967  
1968  
1969  
1970  
1971  
1972  
1973  
1974  
1975  
1976  
1977  
1978  
1979  
1980  
1981  
1982  
1983  
1984  
1985  
1986  
1987  
1988  
1989  
1990  
1991  
1992  
1993  
1994  
1995  
1996  
1997  
1998  
1999  
2000  
2001  
2002  
2003  
2004  
2005  
2006  
2007  
2008  
2009  
2010  
2011  
2012  
2013  
2014  
2015  
2016  
2017  
2018  
2019  
2020  
2021  
2022  
2023  
2024  
2025  
2026  
2027  
2028  
2029  
2030  
2031  
2032  
2033  
2034  
2035  
2036  
2037  
2038  
2039  
2040  
2041  
2042  
2043  
2044  
2045  
2046  
2047  
2048  
2049  
2050

